

LED1200-66-60 epoxy lens type infrared illuminator

LED1200-66-60 is a wide viewing and extremely high output power illuminator assembled with a total of 60 high efficiency InGaAsP diode chips, mounted on a metal stem TO-66 with AlN ceramics and covered with double coated clear silicone and epoxy resin. These devices are designed for high current operation with proper heat sinking to improve thermal conductive efficiency.

Features

High reliability
Compact TO-66 package
High output power at 1200 nm

Applications

IR search light
CCD lighting
Night vision light source

Specifications

Product name	IR illuminator
Spec. No.	LED1200-66-60
Chip Material	InGaAsP
Peak wavelength	1200 nm
Stem	TO-66 stem with AlN
Lens	Clear silicone and epoxy lens

Outer dimension (Unit: mm)

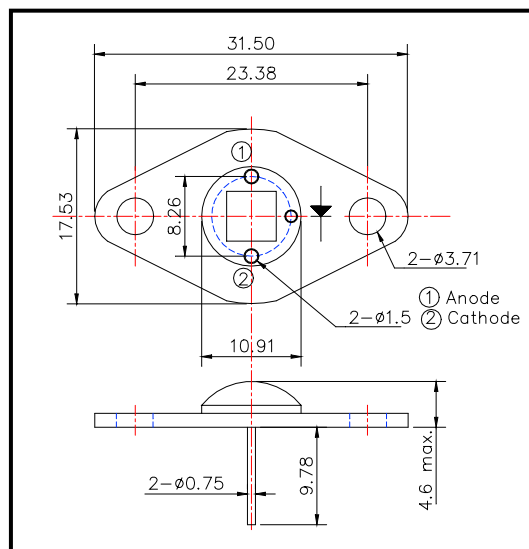

Absolute Maximum Ratings

Item	Symbol	Maximum Rated Value	Unit	Ambient Temperature
Power Dissipation	P _D	7.2	W	T _a = 25°C
Forward Current	I _F	1.2	A	T _a = 25°C
Pulse Forward Current	I _{FP}	12	A	T _a = 25°C
Reverse Voltage	V _R	60	V	T _a = 25°C
Operating Temperature	T _{OPR}	-20 ~ +90	°C	
Storage Temperature	T _{STG}	-30 ~ +100	°C	
Soldering Temperature	T _{SOL}	260	°C	

Pulse Forward Current condition: Duty = 1% and Pulse Width = 1 μs.

Soldering condition : Soldering condition must be completed within 3 seconds at 260°C

Electro-Optical Characteristics

Item	Symbol	Condition	Minimum	Typical	Maximum	Unit
Total Radiated Power	P _O	I _F = 600 mA		210		mW
Total Radiated Power	P _O	I _P = 12 A		-		mW
Radiant Intensity	I _E	I _F = 600 mA		-		mW/sr
Forward Voltage	V _F	I _F = 600 mA		6.6		V
Reverse Current	I _R	V _R = 60 V			10	μA
Peak Wavelength	λ _P	I _F = 600 mA	1150	1200	1250	nm
Spectrum Half Width	Δλ	I _F = 600 mA		100		nm
Viewing Half Angle	2θ _{1/2}	I _F = 600 mA		±60		deg
Rise Time	t _r	I _F = 100 mA		10		ns
Fall Time	t _f	I _F = 100 mA		10		ns

Heat sink is required thermal resistance <8 K/W