

PRELIMINARY

LED590-66-60 epoxy lens type Yellow color illuminator

LED590-66-60 is a wide viewing and extremely high output power illuminator assembled with a total of 60 high efficiency InGaAlP diode chips, mounted on a metal stem TO-66 with AlN ceramics and covered with double coated clear silicone and epoxy resin. These devices are designed for high current operation with proper heat sinking to improve thermal conductive efficiency.

◆ Outer dimension (Unit: mm)

◆ Features

- 1) High reliability
- 2) Compact (TO-66) package
- 3) High output power at 590 nm

◆ Applications

- 1) For high intensity lighting source

◆ Specifications

- 1) Product name Orange color illuminator
- 2) Spec. No. LED590-66-60
- 3) Chip
 - (1) Material InGaAlP
 - (2) Peak wavelength 590 nm
- 4) Package
 - (1) Stem TO-66 stem with AlN
 - (2) Lens Clear epoxy lens

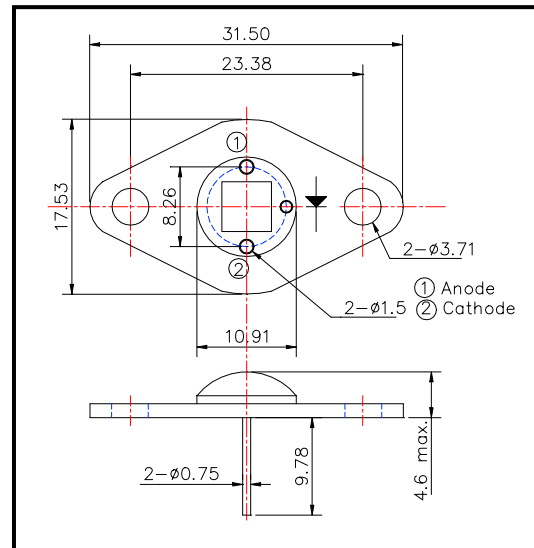

◆ Absolute Maximum Ratings

Item	Symbol	Maximum Rated Value	Unit	Ambient Temp.
Power Dissipation	P _D	4.5	W	T _a = 25 °C
Forward Current	I _F	400	mA	T _a = 25 °C
Pulse Forward Current	I _{FP}	2000	A	T _a = 25 °C
Reverse Voltage	V _R	50	V	T _a = 25 °C
Operating Temperature	T _{OPR}	-30 ~ +80	°C	
Storage Temperature	T _{STG}	-30 ~ +110	°C	
Soldering Temperature	T _{SOL}	240	°C	

‡Pulse Forward Current condition: Duty = 1% and Pulse Width = 1 μs.

‡Soldering condition: Soldering condition must be completed within 3 seconds at 260°C

◆ Electro-Optical Characteristics

Item	Symbol	Condition	Minimum	Typical	Maximum	Unit
Forward Voltage	V _F	I _F = 240 mA		10.0		V
Brightness	I _v	I _F = 240 mA		7000		mcd
Total Radiated Power	P _O	I _F = 240 mA		60		mW
Radiant Intensity	I _E	I _F = 240 mA		15		mW/sr
Reverse Current	V _R	I _R = 10 μA	50			V
Peak Wavelength	λ _P	I _F = 240 mA	580	590	600	nm
Half Width	Δλ	I _F = 240 mA		15		nm
Viewing Half Angle	θ _{1/2}	I _F = 240 mA		±60		deg.

‡Heat sink is required thermal resistance <8K/W

ROITHNER LASERTECHNIK, A-1040 Vienna, Austria, Schoenbrunner Strasse 7
 Tel.: +43-1-586 52 43 - 0, Fax.: +43-1-586 52 43 44
 e-mail: office@roithner-laser.com, http://www.roithner-laser.com