

# ROITHNER LASERTECHNIK

A-1040 VIENNA, SCHOENBRUNNER STRASSE 7, AUSTRIA

TEL: +43 -1- 586 52 43-0 FAX: +43 -1- 586 52 43-44

office@roithner-laser.com www.roithner-laser.com

## LED680-66-60 epoxy lens type infrared illuminator

LED680-66-60 is a wide viewing and extremely high output power illuminator assembled with a total of 60 high efficiency AlGaAs diode chips, mounted on a metal stem TO-66 with AlN ceramics and covered with double coated clear silicone and epoxy resin. These devices are designed for high current operation with proper heat sinking to improve thermal conductive efficiency.

### Features

High reliability
Compact (TO-66) package
High radiant intensity at 680 nm

### Applications

high intensity red lighting source
CCD lighting

### Specifications

Product name	red illuminator
Spec. No.	LED680-66-60
Chip Material	GaAs
Peak wavelength	680 nm
Package	TO-66 stem with AlN stem
Lens	Clear silicone and epoxy lens

Outer dimension (unit: mm)

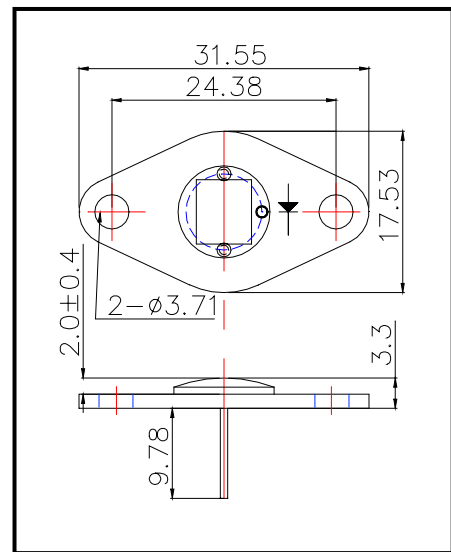

### Absolute Maximum Ratings

Item	Symbol	Maximum Rated Value	Unit	Ambient Temp.
Power Dissipation	P <sub>D</sub>	4.0	W	T <sub>a</sub> = 25°C
Forward Current	I <sub>F</sub>	400	mA	T <sub>a</sub> = 25°C
Pulse Forward Current	I <sub>FP</sub>	2	A	T <sub>a</sub> = 25°C
Reverse Voltage	V <sub>R</sub>	50	V	T <sub>a</sub> = 25°C
Operating Temperature	T <sub>OPR</sub>	-30 ~ +80	°C	
Storage Temperature	T <sub>STG</sub>	-30 ~ +110	°C	
Soldering Temperature	T <sub>SOL</sub>	240	°C	

‡Pulse Forward Current condition: Duty = 1% and Pulse Width = 1 μs.

‡Soldering condition : Soldering condition must be completed within 3 seconds at 260°C

### Electro-Optical Characteristics

Item	Symbol	Condition	Minimum	Typical	Maximum	Unit
Total Radiated Power	P <sub>O</sub>	I <sub>F</sub> = 240 mA		300		mW
Forward Voltage	V <sub>F</sub>	I <sub>F</sub> = 240 mA		9.8		V
Reverse Current	I <sub>R</sub>	V <sub>R</sub> = 50 V	10			μA
Peak Wavelength	λ <sub>P</sub>	I <sub>F</sub> = 240 mA	660	680	700	nm
Half Width	Δλ	I <sub>F</sub> = 240 mA		20		nm
Viewing Half Angle	2φ <sub>1/2</sub>	I <sub>F</sub> = 240 mA		±60		deg.

‡Heat sink is required thermal resistance <8 K/W