

LED690-66-60 epoxy lens type Infrared illuminator

LED690-66-60 is a wide viewing and extremely high output power illuminator assembled with a total of 60 high efficiency AlGaAs diode chips, mounted on a metal stem TO-66 with AlN ceramics and covered with double coated clear silicone and epoxy resin.

These devices are designed for high current operation with proper heat sinking to improve thermal conductive efficiency.

Features

- 1) high reliability
- 2) compact TO-66 package
- 3) high output power at 690 nm

Applications

- 1) medical and biological applications
- 2) CCD lighting

Specifications

- 1) Product name red color illuminator
- 2) Spec. No. LED690-66-60
- 3) Chip
- (1) Material AlGaAs
- (2) Peak wavelength 690 nm
- 4) Package
- (1) Stem TO-66 stem with AlN
- (2) Lens Clear silicone and epoxy lens

Outer dimension (Unit: mm)

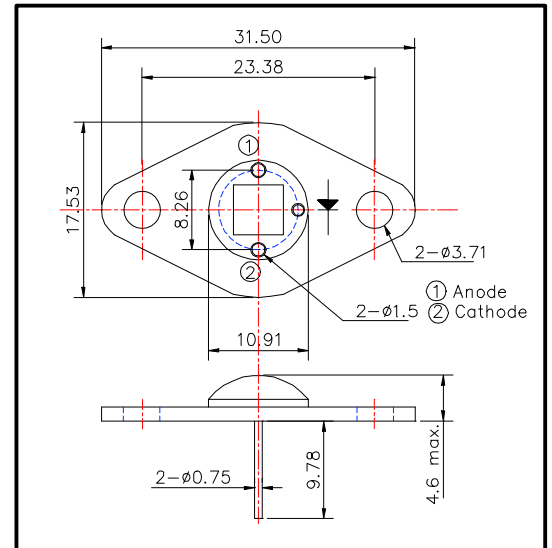

Absolute Maximum Ratings

Item	Symbol	Maximum Rated Value	Unit	Ambient Temperature
Power Dissipation	P _D	4.0	W	T _a = 25°C
Forward Current	I _F	400	mA	T _a = 25°C
Pulse Forward Current	I _{FP}	2.0	A	T _a = 25°C
Reverse Voltage	V _R	50	V	T _a = 25°C
Operating Temperature	T _{OPR}	-30 ~ +80	°C	
Storage Temperature	T _{STG}	-30 ~ +110	°C	
Soldering Temperature	T _{SOL}	240	°C	

‡ Pulse Forward Current condition: Duty = 1% and Pulse Width = 1 μs.

‡ Soldering condition : Soldering condition must be completed within 3 seconds at 260°C

Electro-Optical Characteristics

Item	Symbol	Condition	Minimum	Typical	Maximum	Unit
Forward Voltage	V _F	I _F = 240 mA		9.8		V
Reverse Voltage	V _R	I _R = 10 μA	50			V
Total Radiated Power	P _O	I _F = 240 mA		500		mW
Total Radiated Power	P _O	I _F = 2 A		-----		mW
Radiant Intensity	I _E	I _F = 240 mA		-----		mW/sr
Brightness	I _v	I _F = 240 mA		-----		mcd
Peak Wavelength	I _P	I _F = 240 mA	670	690	710	nm
Half Width	DI	I _F = 240 mA		20		nm
Viewing Half Angle	Q _{1/2}	I _F = 240 mA		±60		deg.

‡ Heat sink is required thermal resistance <8K/W

ROITHNER LASERTECHNIK, A-1040 Vienna, Austria, Schoenbrunner Strasse 7
 Tel.: +43-1-586 52 43 - 0, Fax.: +43-1-586 52 43 44
 e-mail: office@roithner-laser.com, http://www.roithner-laser.com