

LED870-4x4PC66

TECHNICAL DATA

SUPER HIGH POWER INFRARED LED

Structure: **GaAlAs**, 16 power LED chips, 4 x 4 array
 Peak Wavelength: **typ. 870 nm**
 Optical Output Power: **typ. 1.2 W cw @ 1 A**
 Package: **TO-66 stem with silicone resin**

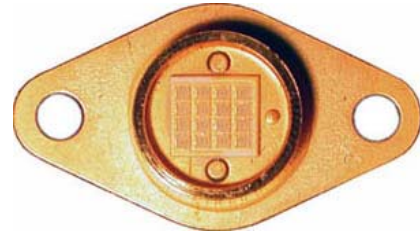
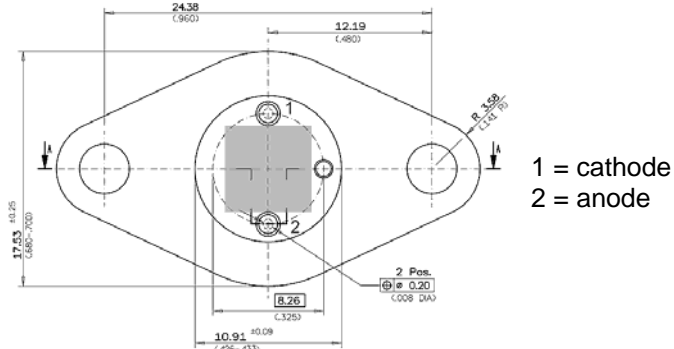

Absolute Maximum Ratings (Tc = 25°C)

CHARACTERISTIC	SYMBOL	RATING	UNIT
Power dissipation	P _D	20	W
DC forward current **)	I _F	1.4	A
Pulse forward current *)	I _{FP}	-	A
Reverse voltage	V _R	5	V
Operating lifetime	T	50.000	h
Operating case temperature	T _{OP}	-30 .. +70	°C
Storage temperature	T _{STG}	-60 .. +85	°C

*) Pulse width ≤ 10 μs, f ≤ 500 Hz

Optical-Electrical Characteristics (Tc = 25°C)

CHARACTERISTIC	SYMBOL	TEST CONDITION	MIN	TYP	MAX	UNIT
Radiant flux	θ _e (870 nm)	I _F = 1 A	1.1	1.2	1.4	W
Luminous flux	θ _v (870 nm)	I _F = 1 A	-	-	-	lm
Luminous intensity	I _v (870 nm)	I _F = 1 A	-	-	-	cd
Forward voltage	V _F	I _F = 1 A	5.6	5.8	6.1	V
Reverse current	I _R	V _R = 5 V			10	μA
Peak wavelength	λ _P	I _F = 1 A	860	870	880	nm
Spectrum half width	Δλ	I _F = 1 A		39		nm
Emission angle FWHM	θ _{1/2}	I _F = 1 A		±60		°

IMPORTANT NOTE FOR SAFE OPERATION

This high power LED must be cooled! **) Use a heat sink with a thermal resistance ≤8K/W. Maximum uncooled allowed operation current ≤80 mA. Do not view directly into the emitting area of the LED when in operation!



ROITHNER LASERTECHNIK

SCHOENBRUNNER STRASSE 7, 1040 VIENNA, AUSTRIA

TEL: +43 -1- 586 52 43-0 FAX: +43 -1- 586 52 43-44

office@roithner-laser.com www.roithner-laser.com