

LED870-66-60 epoxy lens type InfraRed illuminator

LED870—66-60 is a wide viewing and extremely high output power illuminator assembled with a total of 60 high efficiency AlGaAs diode chips, mounted on a metal stem TO-66 with AlN ceramics and covered with double coated clear silicone and epoxy resin. These devices are designed for high current operation with proper heat sinking to improve thermal conductive efficiency.

◆ Features

- 1) High reliability
- 2) Compact (TO-66) package
- 3) High output power at 870nm

◆ Applications

- 1) For IR search light
- 2) For CCD lighting
- 3) For night vision light source

◆ Specifications

- 1) Product name IR illuminator
- 2) Spec. No. LED870-66-60
- 3) Chip
 - (1) Material AlGaAs
 - (2) Peak wavelength 870nm
- 4) Package
 - (1) Stem TO-66 stem with AlN
 - (2) Lens Clear silicone and epoxy lens

◆ Outer dimension (Unit: mm)

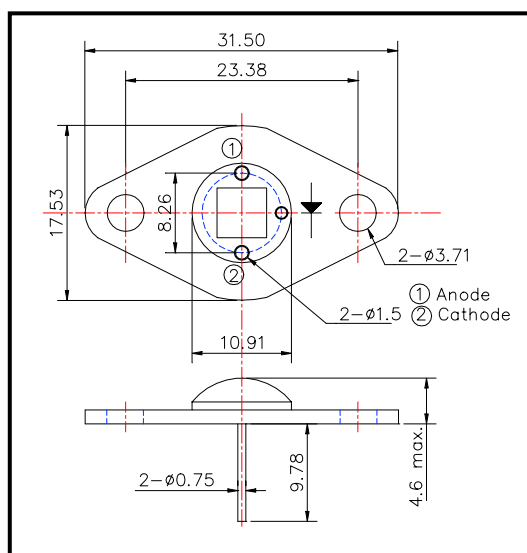

◆ Absolute Maximum Ratings

Item	Symbol	Maximum Rated Value	Unit	Ambient Temp.
Power Dissipation	P _D	7.5	W	T _a =25°C
Forward Current	I _F	1.2	A	T _a =25°C
Pulse Forward Current	I _{FP}	6	A	T _a =25°C
Reverse Voltage	V _R	50	V	T _a =25°C
Operating Temperature	T _{OPR}	-30 ~ +80	°C	
Storage Temperature	T _{STG}	-30 ~ +110	°C	
Soldering Temperature	T _{SOL}	240	°C	

‡Pulse Forward Current condition: Duty=1% and Pulse Width=1us.

‡Soldering condition: Soldering condition must be completed within 3 seconds at 260°C

◆ Electro-Optical Characteristics

Item	Symbol	Condition	Minimum	Typical	Maximum	Unit
Total Radiated Power	P _o	I _F =800mA		1600		mW
Total Radiated Power	P _o	I _F =5A		9500		mW
Radiant Intensity	I _E	I _F =800mA		450		mW/sr
Forward Voltage	V _F	I _F =800mA		7.50		V
Reverse Current	V _R	I _R =10uA	50			V
Peak Wavelength	λ _P	I _F =800mA	860	870	880	nm
Half Width	Δλ	I _F =800mA		40		nm
Viewing Half Angle	θ _{1/2}	I _F =800mA		±60		deg.
Rise Time	••	I _F =100mA		15		ns
Fall Time	••	I _F =100mA		10		ns

‡Heat sink is required thermal resistance <8K/W

ROITHNER LASERTECHNIK, A-1040 Vienna, Austria, Schoenbrunner Strasse 7
 Tel.: +43-1-586 52 43 - 0, Fax.: +43-1-586 52 43 44
 e-mail: office@roithner-laser.com, http://www.roithner-laser.com