

LED940-66-60 epoxy lens type Infrared illuminator

LED940-66-60 is a wide viewing and extremely high output power illuminator assembled with a total of 60 high efficiency AlGaAs diode chips, mounted on a metal stem TO-66 with AlN ceramics and covered with double coated clear silicone and epoxy resin.

These devices are designed for high current operation with proper heat sinking to improve thermal conductive efficiency.

Features

- 1) high reliability
- 2) compact TO-66 package
- 3) high output power at 940 nm

Applications

- 1) For IR search light
- 2) For CCD lighting

Specifications

- 1) Product name IR illuminator
- 2) Spec. No. LED940-66-60
- 3) Chip
 - (1) Material GaAs
 - (2) Peak wavelength 940 nm
- 4) Package
 - (1) Stem TO-66 stem with AlN
 - (2) Lens Clear silicone and epoxy lens

Outer dimension (Unit: mm)

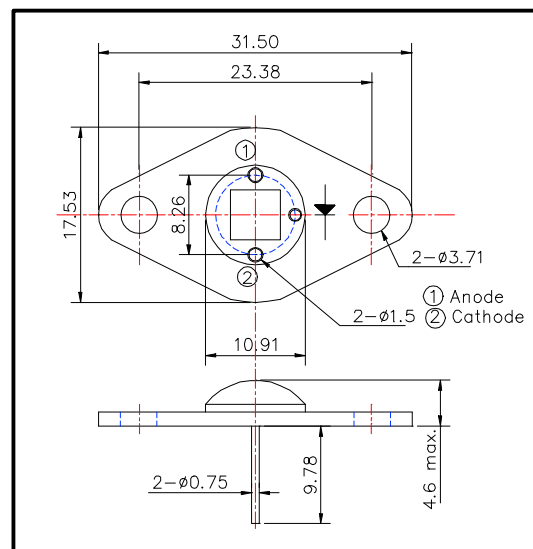

Absolute Maximum Ratings

Item	Symbol	Maximum Rated Value	Unit	Ambient Temperature
Power Dissipation	P _D	7.5	W	T _a = 25°C
Forward Current	I _F	1.0	A	T _a = 25°C
Pulse Forward Current	I _{FP}	5.0	A	T _a = 25°C
Reverse Voltage	V _R	50	V	T _a = 25°C
Operating Temperature	T _{OPR}	-30 ~ +80	°C	
Storage Temperature	T _{STG}	-30 ~ +100	°C	
Soldering Temperature	T _{SOL}	240	°C	

‡ Pulse Forward Current condition: Duty = 1% and Pulse Width = 1 μs.

‡ Soldering condition : Soldering condition must be completed within 3 seconds at 260°C

Electro-Optical Characteristics

Item	Symbol	Condition	Minimum	Typical	Maximum	Unit
Forward Voltage	V _F	I _F = 800 mA		7.1		V
Reverse Voltage	V _R	I _R = 10 μA	50			V
Total Radiated Power	P _O	I _F = 800 mA		1200		mW
Total Radiated Power	P _O	I _F = 5 A		7000		mW
Radiant Intensity	I _E	I _F = 800 mA		350		mW/sr
Brightness	I _v	I _F = 800 mA		----		mcad
Peak Wavelength	I _P	I _F = 800 mA	930	940	955	nm
Half Width	DI	I _F = 800 mA		40		nm
Viewing Half Angle	Q _{1/2}	I _F = 800 mA		±60		deg.

‡ Heat sink is required thermal resistance <8K/W

ROITHNER LASERTECHNIK, A-1040 Vienna, Austria, Schoenbrunner Strasse 7
 Tel.: +43-1-586 52 43 - 0, Fax.: +43-1-586 52 43 44
 e-mail: office@roithner-laser.com, http://www.roithner-laser.com