

AlGaInP Ultra Bright Red LED Lamp

OPE5T64UR

The **OPE5T64UR** is AlGaInP ultra bright light emitting diode that is designed for ultra brightness and excellent reliability. This device is optimized for efficiency at peak wavelength 639nm.

This device is packaged T13/4 plastic package and has narrow beam angle with lensed package and cup frame.

FEATURES

- Ultra brightness
- Peak wavelength : 639nm
- Narrow beam angle
- Excellent reliability
- Available for pulse operating

APPLICATIONS

- PIXEL cluster
- LED Dot Matrix
- Traffic signal
- Display signboard

STORAGE

- Condition : 5°C~35°C,R.H.60%
- Terms : within 3 months from production date
- Remark : Once the package is opened, the products should be used within a day.
Otherwise, it should be keeping in a damp proof box with desiccants.

* Please take proper steps in order to secure reliability and safety in required conditions and environments for this device.

DIMENSIONS (Unit : mm)

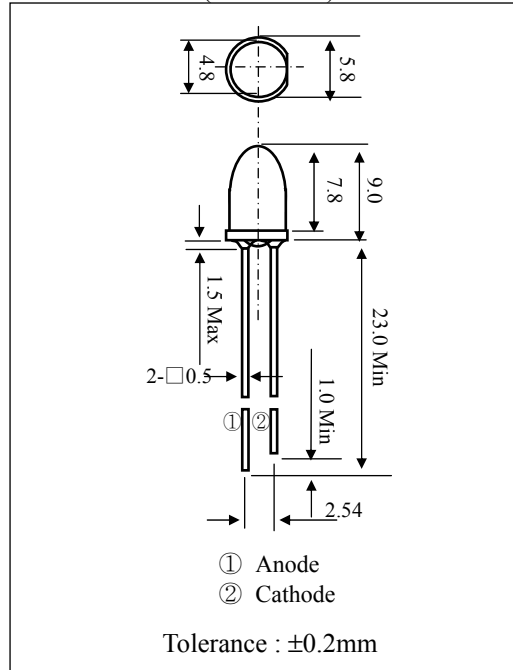

MAXIMUM RATINGS

(Ta=25°C)

Item	Symbol	Rating	Unit
Power dissipation	P_D	40	mW
Forward current	I_F	30	mA
Pulse forward current *1	I_{FP}	50	mA
Reverse voltage	V_R	4	V
Operating temp.	$T_{opr.}$	-25~ +85	°C
Soldering temp. *2	$T_{sol.}$	260.	°C

*1.Duty ratio = 1/100, pulse width=0.1ms.

*2.Lead soldering temperature (2mm from case for 5sec.).

ELECTRO-OPTICAL CHARACTERISTICS

(Ta=25°C)

Item	Symbol	Conditions	Min.	Typ.	Max.	Unit
Luminous intensity	I_v	$I_F=20mA$				mcd
Peak emission wavelength	λ_p	$I_F=20mA$		639		nm
Spectral bandwidth	$\Delta\lambda$	$I_F=20mA$		20		nm
Forward voltage	V_F	$I_F=20mA$		2.0	2.3	V
Reverse current	I_R	$V_R=4V$			100	μA
Half angle	$\Delta\theta$	$I_F=20mA$		±8		deg.

● FORWARD CURRENT Vs. AMBIENT TEMP

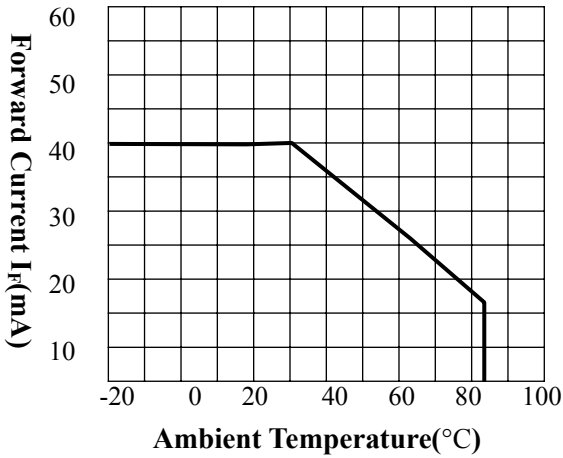

● LUMINOUS INTENSITY Vs. FORWARD CURRENT

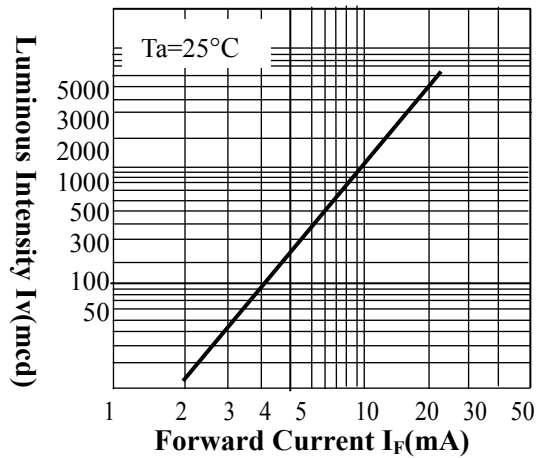

● RELATIVE LUMINOUS INTENSITY Vs. AMBIENT TEMP.

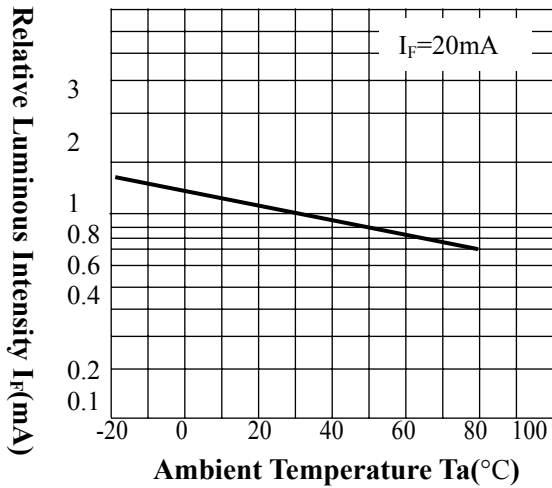

● RELATIVE LUMINOUS INTENSITY Vs. EMISSION WAVELENGTH.

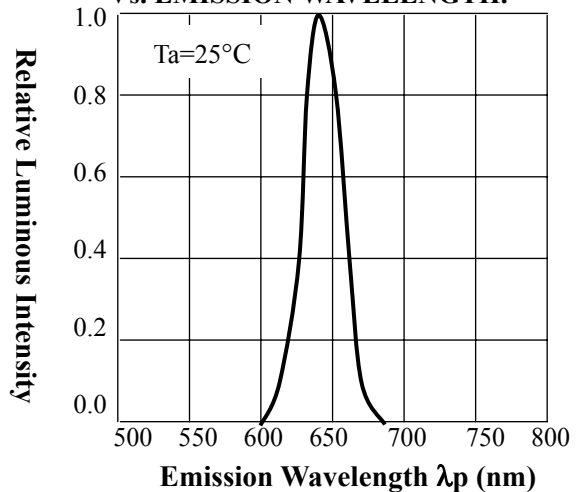

● FORWARD CURRENT Vs. FORWARD VOLTAGE

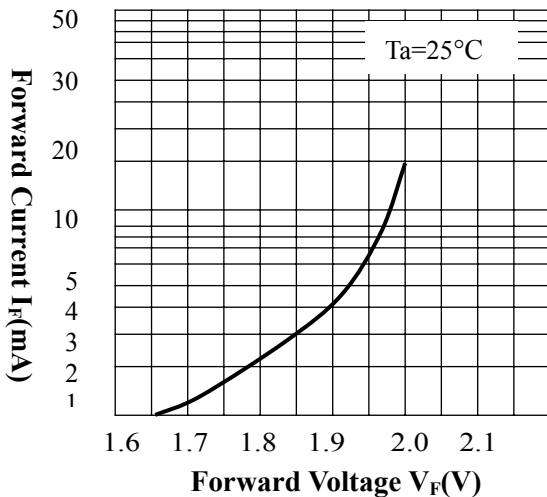

● RELATIVE LUMINOUS INTENSITY Vs. ANGULAR DIAPLACEMENT

