

# Multi-Quantum Well (MQW) Laser Diode

## Specification

**Model: ELD83NPT50**

**ROITHNER LASERTECHNIK**

A-1040 Vienna, Austria  
Schoenbrunner Strasse 7  
Tel.: +43-1-586 52 43 - 0  
Fax.: +43-1-586 52 43 44  
e-mail: [office@roithner-laser.com](mailto:office@roithner-laser.com)  
<http://www.roithner-laser.com>

**2002.6**

**Catalog**

1. **Scope**.....3

2. **Outline Dimensions and Terminal Connections** .....3

3. **Ratings and Characteristics** .....4

4. **Reliability** .....5

5. **Incoming inspection** .....6

6. **Supplements**.....7

7. **Operation note** .....8

8. **Quality assurance** ..... 8

9. **Security** .....9

10. **Note** .....9

**1. Scope**□

The specification covers the appearance and characteristics of 830nm Laser Diode used as light source, It's model is ELD83NPT50. This product is packaged with an ALGaAs multiple quantum well invisible laser diode chip and a silicon photodiode for monitoring optical power output. Oscillation transverse mode of this model is TE.

## 2. Outline Dimensions and Terminal Connections

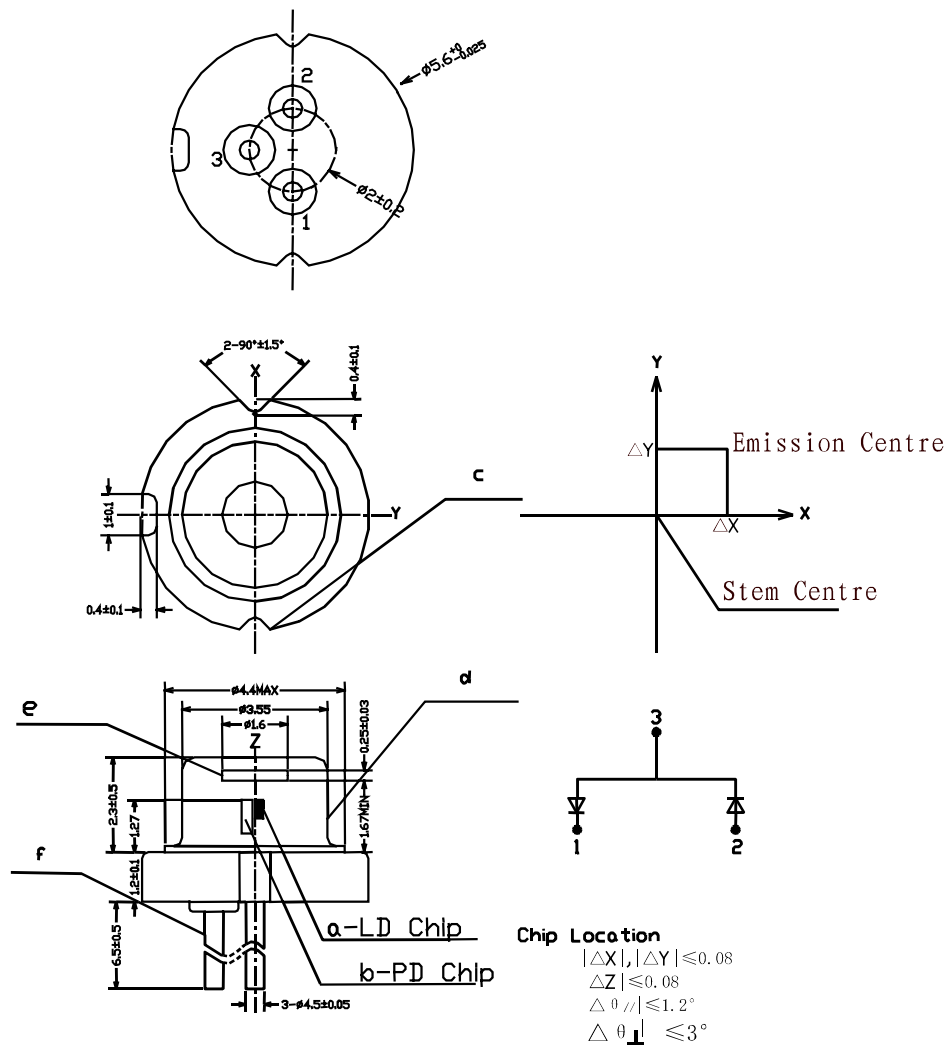

Average single quality 0.31g

General tolerance  $\pm 0.2$  Unit = mm

No.	Component	Material	finish
a	Laser diode chip	AlGaAs	
b	Photodiode chip	Si	
c	Stem	Fe	Gold-plated
d	Cap	Kovar	Nickel-plated
e	Window glass	Glass	$n = 1.49$ (Typ. $\lambda = 650\text{nm}$ )
f	Lead pins	Kovar	Gold-plated

## 3. Ratings and Characteristics

**3-1 Absolute Maximum Ratings**

(Tc=25°C (case temperature))

Parameter		Symbol	Value	Unit
Optical power output (CW)		Po	60	mW
Reverse voltage	Laser diode	Vrl	2	V
	Photodiode	Vrd	30	V
Operating temperature temperature	temperature case	Tc	-10 ~ +55	°C
Storage temperature temperature		Tstg	-40 ~ +85	°C

**3-2 Electro-optical Characteristics** Note 1

Tc=25°C

Parameter	Condition	Symbol	Min.	Typ.	Max	Unit
Threshold current	CW	I <sub>th</sub>	-	20	30	mA
Operating current	Po=50mW CW	I <sub>op</sub>	-	100	160	mA
Operating voltage		V <sub>op</sub>	-	1.8	2.5	V
Wavelength		λ <sub>p</sub>	820	830	840	nm
Lateral Beam Angle Note 2, 3		θ <sub>l</sub>		12	16	Degree
Vertical Beam Angle Note 2, 3		θ <sub>v</sub>		25	35	Degree
Monitor current		I <sub>m</sub>		350	800	μA
Slope efficiency	CW	η <sub>d</sub>	0.4	0.65	0.8	

Note 1 Initial value, Continuous Work.

Note 2 Angle of 50% peak intensity Full angle at half-maximum

Note 3 Parallel to the junction plane X-Z plane

perpendicular to the junction plane Y-Z plane

## 4. Reliability

### 4-1 The reliability of product satisfy all the items listed below.

Reliability  $\geq 90\%$

No.	Test	Test Conditions	Reference Standard	Sampler: n	Defective C	LTPD (%)
1	Solder ability	Soldering temperature $\geq 250 \pm 5$ Immersion time $\geq 5 \pm 0.5$ second brand iron should be grounded	GJB-128A	11	0	20
2	Terminal strength <input type="checkbox"/> Tensile test <input type="checkbox"/>	Load $\geq 5N$ Duration $\geq 10 \pm 1s$ Once for each terminal	GB-4937	11	0	20
3	Terminal strength <input type="checkbox"/> Bending test <input type="checkbox"/>	Load $\geq 2.5N$ $0^\circ \sim 90^\circ \sim 0^\circ \sim 90^\circ \sim 0^\circ$ Once for each terminal	GB-4937	11	0	20
4	Mechanical shock	Acceleration $\geq 14,700m/s^2$ Pulse width $\geq 0.5ms$ Direction :X,Y,Z Five times for each direction	GJB-548A	11	0	20
5	Variable frequency vibration	Acceleration $\geq 196m/s^2$ Frequency $\geq 20 \sim 2000 \sim 20Hz$ 4min reciprocation $\geq X,Y$ and Z Four times for each direction	GJB-548A	11	0	20
6	Temperature cycling	Lower temperature $\geq 40$ Higher temperature $\geq 85$ Duration $\geq 5$ times $\geq$ stay for 3h switch time:3min	GB-2423.22	11	0	20
7	Sealing	Helium gas to detect fine leaks: $5 \times 10^{-3} Pa \cdot cm^2/s$ In fluorocarbon liquid $125 \pm 5$ no bubble	GJB-128A	11	0	20
8	High temperature	Storage temperature $\geq 85$ t $\geq 96$ H	GB-2423.2	11	0	20
9	Low temperature	Storage temperature $\geq 40$ t $\geq 96$ H	GB-2423.1	11	0	20
10	Moisture resistance (temperature humidity cycle)	Duration :From normal temperature up to $55$ in 3h,stay for 9h,down to $25$ in 3h stay for 9h. Repeat 6 times. $\geq$ humidity is $95\%$	GB-2423.4	11	0	20

### 4-2 Parameters to be measured and Failure criteria

No.	Parameters	Failure judgment criteria
1	Operating current	$I_{op} \geq$ Initial operating current $\times 1.2$
2	Operating voltage	$V_{op} \geq$ Initial operating voltage $\times 1.1$
3	Monitor current	$I_m \geq$ Initial operating value $\times 0.8$ or $I_m \geq$ Initial operating value $\times 1.2$

\* Solder ability test: Solder must cover at least 95% of the total immersed area.

\* Terminal strength test( Tension/Bending);Terminal shall not be destroyed or loosened.

### 4-3 Target Lifetime

The target mean time to failure(MTTF)of this product is more than three thousand hours. MTTF is to be confirmed by performing the operating test under the following conditions once in six months. Samples tested should have a laser diode chip with the same structure of this model.

Note 1  Defective samples caused by surge current is rejected .

## 5. Incoming inspection

**5-1 Inspection standards :** GB-2828-87 ,Normal inspection,1 time sample scheme.

**5-2 Inspection level:** II

**5-3 AQL**

5-3-1 Definition of the lot  
the day shipping the product

5-3-2 Characteristics

AQL(%)	Parameter	Failure judgment criteria
1.0	lth, lop, Vop,ηd, λp, θ□, θ±□lm	Not conforming to the specification

5-3-3 Appearance

AQL(%)	Failure judgment criteria
1.0	Parameters of stem and cap are not conforming the specification rust□cracking□dirt□bend

\* Inspection is performed after blowing the window glass.

**6 Supplements**

6.1 ODS materials

This product shall not contain the following materials. Also the following materials shall not be used in the production process for this product.

Materials for ODS: CFCs□Halon□Carbon tetrachloride ,etc.

6.2 Brominated flame retardants

6.3 Packing

6.3.1 Packing method

- 1□ Laser diodes are packaged in an Anti-Static-plastic box.
- 2□ Each Anti-Static-plastic box can accommodate 100 laser diodes maximum.
- 3□ 5 Anti-Static-plastic box is piled up together and enlaced with an Elastic band.
- 4□ The above bound boxes are stuffed into a clean Anti-Static-bag ,then this is vacuumized and sealed thermally.
- 5□ Each packing case can accommodate 500 laser diodes, which is the minimum unit of packing. labels where the model number, quantity and lot number are printed are struck on both of the bag and on the case□refer to 6.3.4□.

6.3.2 Packing materials

No.	Component parts	Material
1	Laser tray	Conductive polystyrene resin
2	Package bag	Anti-static plastic
3	Package box	cardboard

6.3.3 Case appearance

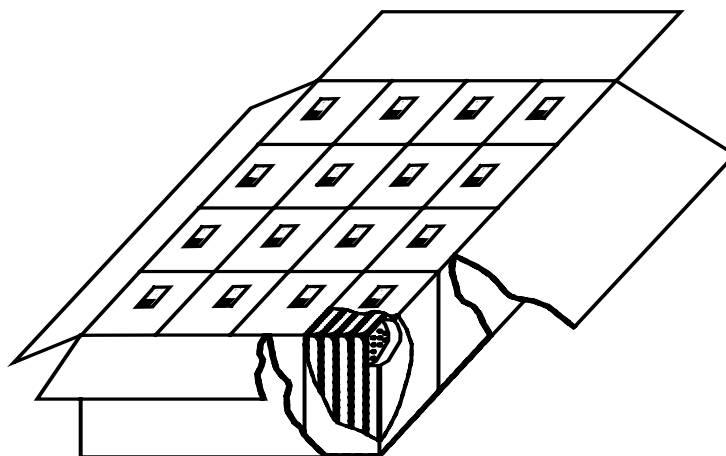

6.3.4 Label

- 1□ A label on the clean-bag

<b>MODEL:</b>		<b>LOT NO :</b>	
<b>Po:</b>	mW	<b>CHIP LOT</b>	<b>QTY(PCS)</b>
<b>M . Date:</b>			
<b>QTY:</b>	pcs		

packing case

<b>TO</b>					
TYPE		G.WT			
QTY		N.WT			
LOT No.		L	38	cm	
M.Date		W	29	cm	
C/No.		H	14.5	cm	

## 7. Operation note

### 7.1 Absolute maximum ratings

If an excessively large current flows in a laser diode, a large optical output will occur and the emitting facet may sustain damage. This optical damage can occur even with momentary over-current. For this reason, absolute maximum ratings which must not be exceeded even momentarily have been established. Exercise particular caution with respect to the drive voltage supply and static electricity. We guarantee use within the absolute maximum ratings. These ratings are established for a case temperature of 25°. As the temperature of a laser diode increases, its maximum output will decrease and the operating range will shrink. Even when operated within the absolute maximum ratings, operation at high temperature will result in a shorter life than operation at low temperature. For this reason, the design should include sufficient margin for heat radiation and light output.

### 7.2 Heat radiation conditions

Like other semiconductors, prolonged operation of a laser diode will cause heat to build up at junctions and increased case temperature. For this reason, attach aluminum, copper (or other) heat sinks (at least 30 × 30 × 3mm) to the stem of the laser.

### 7.3 Protection against damage due to electrostatic discharge and other current surges

Electrostatic discharge and other current surges can cause deterioration and damage in laser diodes, resulting in reduced reliability. We advise taking the following protective measures :

7.3.1 Ground the device and circuits. Install surge filters, surge reduction transformers, or other electrostatic discharge protectors in the power supply inputs.

7.3.2 When working with laser diodes wear anti-static clothing, including footwear and caps. Materials should be selected carefully. Grounded wrist should always be worn while working with laser diodes, and the strap should be grounded through a 1 MΩ resistance.

7.3.3 Use anti-static containers for transport and storage.

7.3.4 Laser deterioration and damage can occur due to excessive current spikes when the power is turned on or off. Design circuits to avoid the generation of excessive current spikes.

7.3.5 Inductive surges near equipment that emits high frequency EMI can damage or destroy lasers. Avoid using lasers near fluorescent lamps or other sources of EMI emissions.

### 7.4 Soldering

Use a grounded soldering iron to solder laser leads. Solder at a temperature of no more than 250° for a maximum of 3 seconds, at a point at least 2 mm from the base of the leads .

### 7.5 Handling laser diodes

7.6 Never touch the glass window of the laser. A damaged or dirtied window will impair the performance of the laser.

#### **7.6 Handling packages**

Due to the glass window in each device, packages must not be dropped or subjected to excessive pressure.

#### **7.7 Safety**

It is extremely dangerous to look, either directly or through a lens, at the laser beam emitted from a laser diode. Use a TV camera or other similar device to adjust the optical axis.

### **8. Quality assurance**

8.1 Laser diodes (semiconductor lasers) have a much longer life than other lasers such as gas or solid-state lasers. The components of our lasers have optimum characteristic ranges. To ensure these characteristics and product life, we manufacture our laser diodes based on comprehensive data control using our own custom manufacturing, measuring, and inspection equipment.

#### **8.2 Quality assurance system**

8.2.1 After the wafers have been manufactured, electrical and optical characteristics are measured to verify that characteristics can be achieved as the manufacturing process progresses.

8.2.2 In-process inspections are conducted at various manufacturing points to ensure the stability of our assembly operations.

8.2.3 All products are burned-in to minimize initial and random failures.

8.2.4 Characteristics of all products are tested before shipping.

8.2.5 Products are managed by wafer lot.

8.2.6 Reliability tests are performed on randomly selected samples.

#### **8.3 Quality assurance measures**

8.3.1 Materials, manufacturing conditions, and inspection are controlled and maintained based on company set standards. Temperature, dust, humidity and other environmental conditions are also controlled based on company standards.

8.3.2 Measurement instruments used during the manufacturing process are regularly inspected and calibrated based on company measurement control standards.

### **9. Security**

The laser beam emitted from a laser diode is almost invisible to both the human eye and the animal eye, however, it will injure the eye and sufficient caution must be exercised to avoid direct exposure or exposure through a fiber to the beam when a laser diode is in operation.

To adjust the optical axis or perform other similar work, we recommend using an infrared-sensitive ITV camera.

We also recommend that protective glasses be worn

### **10. Note**

10.1 No unauthorized transmission or reproduction of this specification, either in whole or in part, is permitted.

10.2 The contents of these sheets are subject to change without notice. Always verify before use that the contents are the latest specifications. If, by any chance, a defect should arise in the equipment as a result of use without verification of the specifications, manufacturer, can bear no responsibility whatsoever.

10.3 Upon the sale of any such devices; other than for the buyer's right to use such devices itself, resell or otherwise dispose of the same; no express or implied right or license to practice or commercially exploit any intellectual property rights or other proprietary rights owned or controlled by us, is granted to any such buyer.

10.4 The products listed in this specification are designed to be used with ordinary electronic equipment or devices (such as audio-visual equipment, office-automation equipment, communications devices, electrical appliances, and electronic toys). Should you intend to use these products with equipment or devices which require an extremely high level of reliability and the malfunction of which would directly endanger human life (such as medical instruments, transportation equipment, aerospace machinery, nuclear-reactor controllers, fuel controllers, or other safety devices) please be sure to consult with our sales representatives in advance.

10.5 when exporting, please be sure to consult with our sales representatives to ascertain whether any product is classified as a strategic material.