

PD035P96 hermetical sealing type photo-diode

PD035P96 is a PIN-photodiode featuring excellent responsibility and high photocurrent. This PIN-photodiode consists of a large chip with 3.0mm*3.0mm active area mounted on the TO-39 stem and is hermetical sealed by metal can with flat lens.

These devices are designed to be easy of setting up optically with a wide angle of half sensitivity of ± 50 degrees.

◆Outer dimension (Unit: mm)

◆Specifications

- 1) Product Name Stem Type Photo-Diode
- 2) Type No. PD035P96
- 3) Chip
 - (1) Chip Size 3.5mm*3.5mm
 - (2) Active Area 3.0mm*3.0mm
- 4) Package
 - (1) Type TO-39
 - (2) Lens Glass Flat Lens
 - (3) Cap Gold Plated

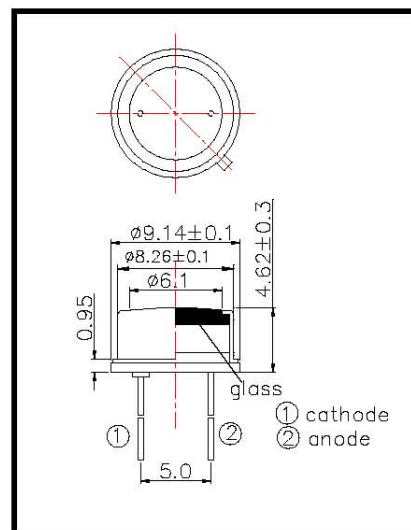

◆Absolute Maximum Ratings [Ta=25°C]

Item	Symbol	Maximum Rated Value	Unit
Reverse Breakdown Voltage	$V_{(BR)R}$	170	V
Operating Temperature	T_{OPR}	-25 ~ +100	°C
Storage Temperature	T_{STG}	-30 ~ +125	°C
Soldering Temperature	T_{SOL}	240	°C

±Soldering condition: Soldering condition must be completed within 2 seconds at 240°C

◆Electro-Optical Characteristics [Ta=25°C]

Item	Symbol	Condition	Minimum	Typical	Maximum	unit
Reverse Photo Current	I_L	$V_R=10V, L=1000Lx$		110		uA
Reverse Dark Current	I_D	$V_R=10V$		5	30	nA
Open Circuit Voltage	V_{OC}	$V_R=10V, L=1000Lx$		350		mV
Spectral Responsivity (Peak)	λ_P			900		nm
Half Angle of Sensitivity	$\theta_{1/2}$			± 50		deg.
Total Capacitance	C_T	$V_R=10V, f=1MHz$		25		pF
Rise/Fall Time(10%~90%)	t_r	$R_L=1K\Omega, V_R=10V$		300		ns
	t_f			600		ns