

# Ultraviolet selective SiC based UV sensor

## SIC01L-5

---



### **Features**

- Broad band UVA-UVB-UVC photodiode in TO5 metal package
- Silicon Carbide based chip for extreme radiation hardness
- Chip dimensions of  $1 \times 1 \text{ mm}^2$  with  $0.96 \text{ mm}^2$  active area
- Intrinsic visible blindness due to wide-bandgap semiconductor material
- Completely insensitive to the visible ( $S_{280\text{nm}} / S_{400\text{nm}} > 10^4$ ) without filters
- The chip is manufactured by Cree Research Inc., U.S.A.

### **Eigenschaften**

- Breitband UVA-UVB-UVC Photodiode im TO5 Metallgehäuse
- Siliziumkarbidchip garantiert extreme Strahlungsfestigkeit
- Chipabmessungen von  $0.5 \times 0.5 \text{ mm}^2$  mit  $0.22 \text{ mm}^2$  aktiver Fläche
- hohe intrinsische Unempfindlichkeit gegenüber dem sichtbaren Licht durch Halbleitermaterial mit hoher Bandlücke
- Vollständig unempfindlich für sichtbares Licht ( $S_{280\text{nm}} / S_{400\text{nm}} > 10^4$ ) ohne Filtereinsatz
- Chiphersteller: Cree Research Inc., U.S.A.

# Ultraviolet selective SiC based UV sensor

## SIC01L-5

### Maximum Ratings

Parameter	Symbol	Value	Unit
Operating temperature range	$T_{opt}$	-25 ... +70	°C
Reverse voltage	$V_{Rmax}$	20	V

### General Characteristics

( $T_a = 25\text{ °C}$ )

Parameter	Symbol	Value	Unit
Active area	A	0.96	mm <sup>2</sup>
Dark current at 1 V reverse bias	$I_d$	5	fA
Capacitance	C	200	pF
Short circuit current at bright sun	$I_0$	ca. 800	nA

### Spectral Characteristics

( $T_a = 25\text{ °C}$ )

Parameter	Symbol	Value	Unit
Max. spectral sensitivity	$S_{max}$	0.13	A W <sup>-1</sup>
Wavelength of max. spectral sensitivity	$\lambda_{Smax}$	280	nm
Range of spectral sensitivity ( $S=0.1*S_{max}$ )	-	220 - 360	nm

# Ultraviolet selective SiC based UV sensor

## SIC01L-5

---

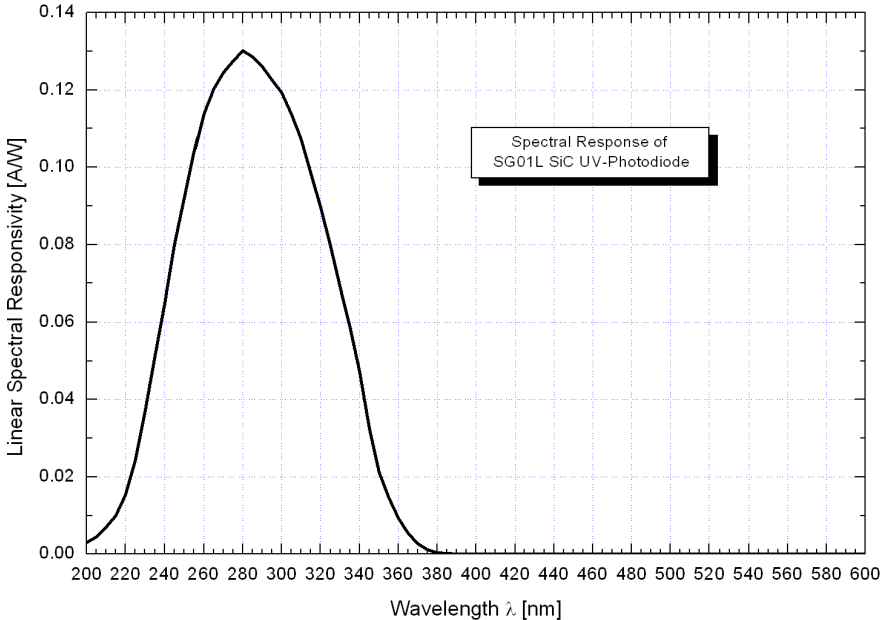

### *Logarithmic Spectral Response*

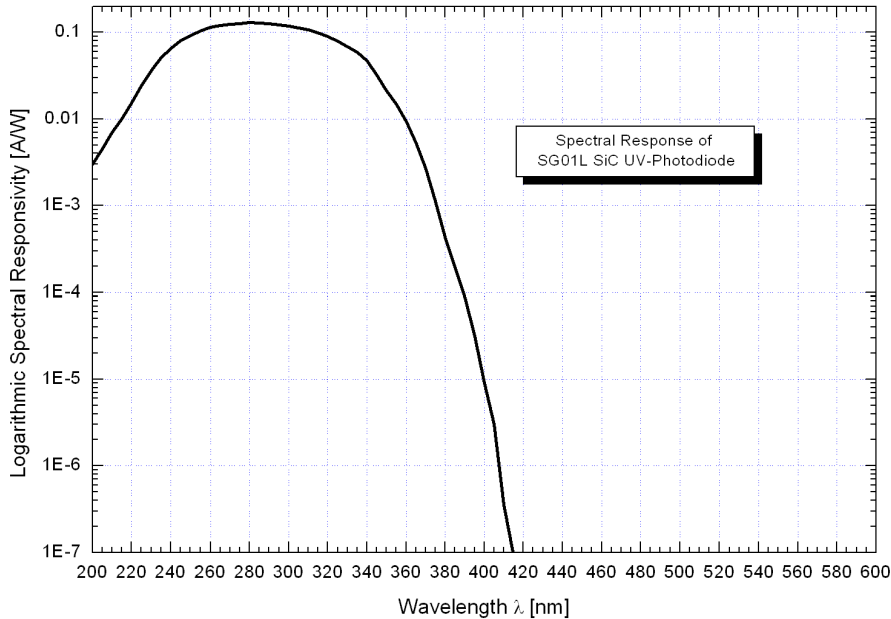

# Ultraviolet selective SiC based UV sensor

## SIC01L-5

### Application Example

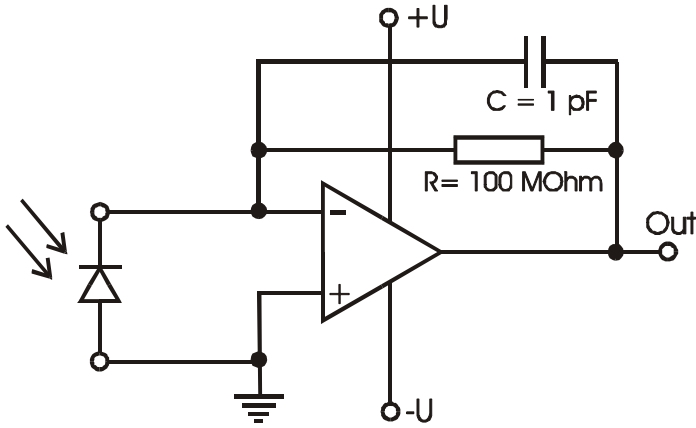

### Pin Layout

