

UVC-selective SiC based UV sensor

SIC01M-C

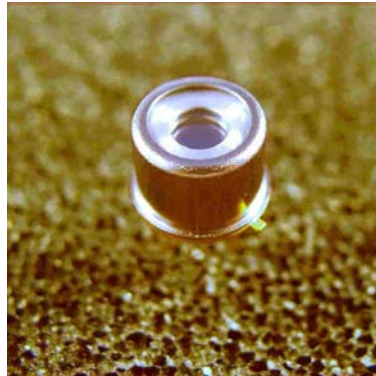

Features

- UVC Photodiode with medium-sized photoactive area
- Good compromise between signal strength and price
- Silicon Carbide based chip for extreme irradiation hardness
- Spectral Response in accordance with DVGW W 294
- TO-39 metal package with $0.5 \times 0.5 \text{ mm}^2$ SiC chip
- The chip is made by Cree Research Inc., U.S.A.
- Radiation-hard UVC interference filter is made in Germany

Eigenschaften

- UVC Photodiode mit mittelgroßer photoaktiver Fläche
- Guter Kompromiss zwischen Signalstärke und Preis
- Siliziumcarbid-Chip garantiert extreme Strahlungsfestigkeit
- Spektrale Empfindlichkeit in Übereinstimmung mit DVGW W 294
- TO-39 Metallgehäuse mit $0.5 \times 0.5 \text{ mm}^2$ SiC chip
- Chiphersteller: Cree Research Inc., U.S.A.
- Der strahlungsharte Interferenzfilter wird in Deutschland hergestellt

UVC-selective SiC based UV sensor

SIC01M-C

Maximum Ratings

Parameter	Symbol	Value	Unit
Operating temperature range	T_{opt}	-25 ... +80	°C
Reverse voltage	V_{Rmax}	20	V

General Characteristics

($T_a = 25\text{ °C}$)

Parameter	Symbol	Value	Unit
Filter aperture	D	3.6	mm
Active area	A	0.22	mm ²
Dark current at 1 V reverse bias	I_d	2	fA
Capacitance	C	80	pF
Short circuit current for 1 mW/cm ² @ 254 nm	I_0	ca. 130	nA

Spectral Characteristics

($T_a = 25\text{ °C}$)

Parameter	Symbol	Value	Unit
Max. spectral sensitivity	S_{max}	0.11	A W ⁻¹
Wavelength of max. spectral sensitivity	λ_{Smax}	270	nm
Range of spectral sensitivity ($S=0.1*S_{max}$)	-	230 - 285	nm

Linear Spectral Response

UVC-selective SiC based UV sensor

SIC01M-C

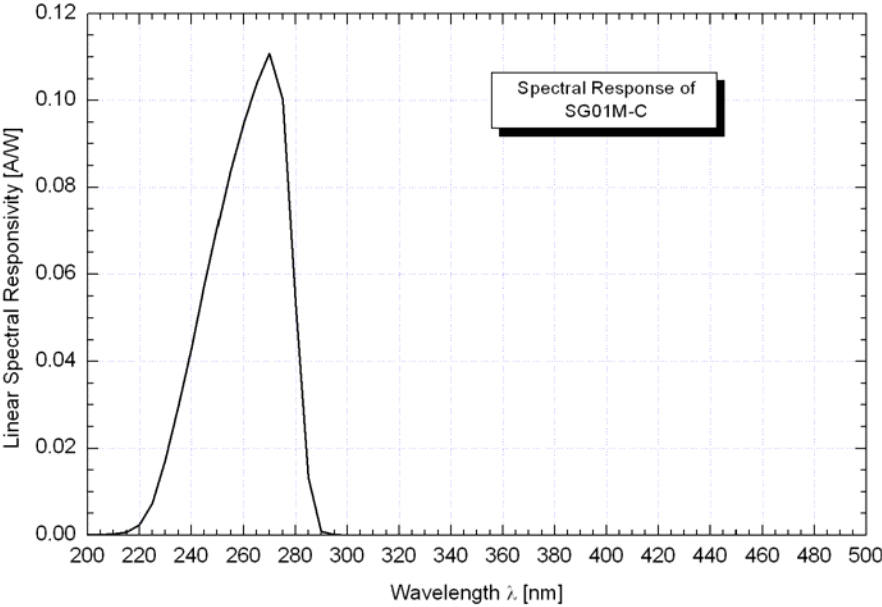

Logarithmic Spectral Response

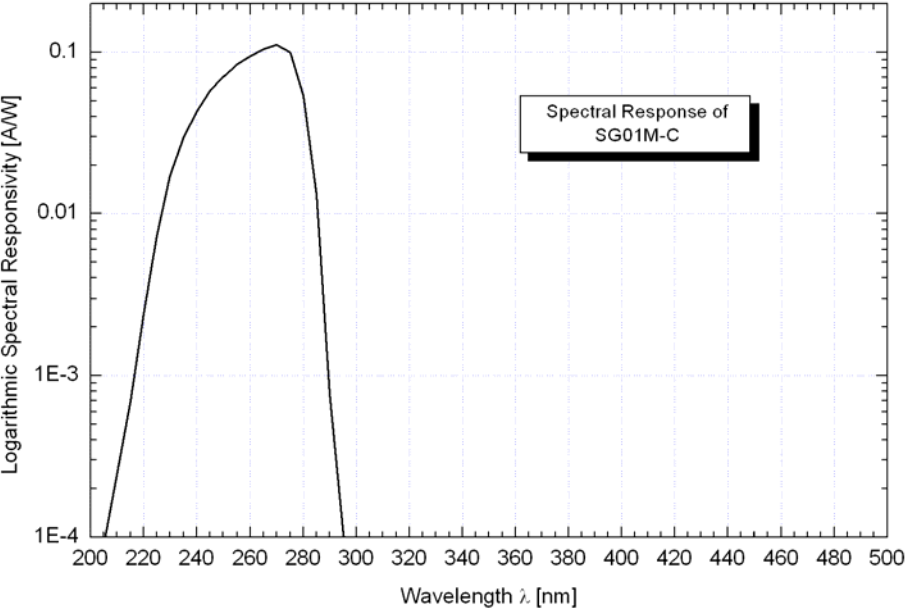

UVC-selective SiC based UV sensor

SIC01M-C

Application Example

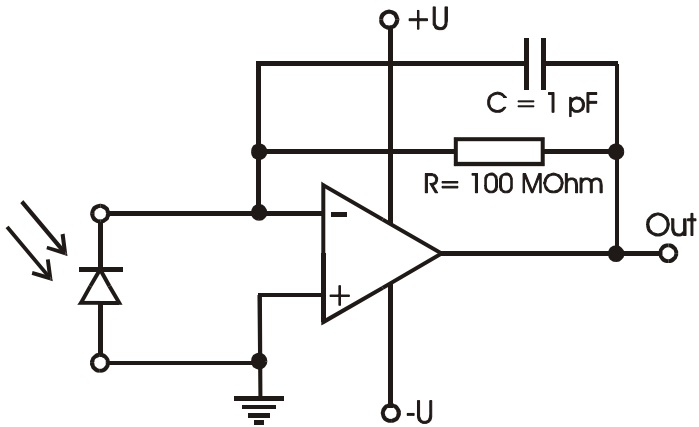

Pin Layout

