

PM85-D1P0U

850nm VCSEL Dome Lens Can Package

Features

- : 850nm wavelength range
- : Narrow beam angle
- : High output power
- : Cost effective TO can
- : Other configurations available on request

Applications

- : Position Sensing
- : Encoder

Description

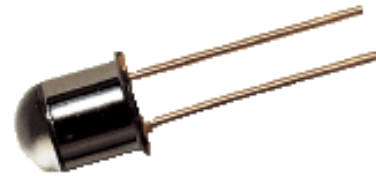

Absolute Maximum Ratings

Parameter	Rating
Storage Temperature	-40 to 100 °C
Operating Temperature	0 to 85 °C
Lead Solder Temperature	260 °C, 10 sec
Continuous Forward Current	12mA
Continuous Reverse Voltage	5V (@10μA)

PM85-D1P0U

850nm VCSEL Dome Lens Can Package

Dimensions

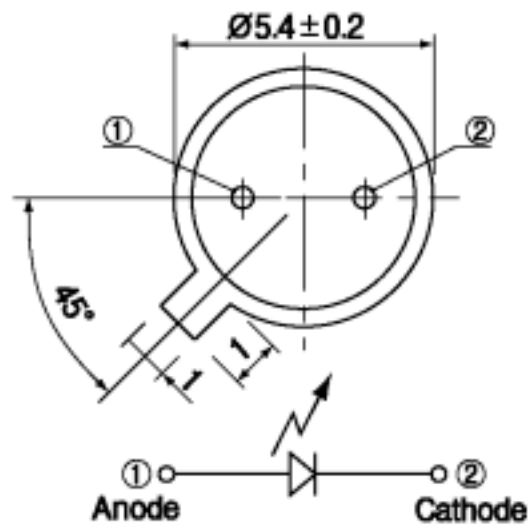
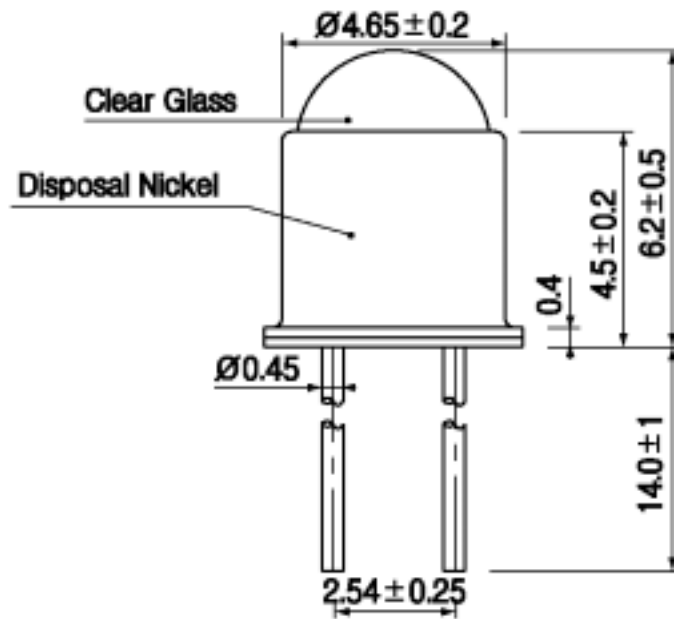

Electro-Optics Characteristics ($T_a=25^{\circ}\text{C}$ unless otherwise stated)

Parameters	Symbol	Specified			Unit	Test Conditions
		Min.	Typ.	Max.		
Threshold Current	I_{th}		1.5	3	mA	CW
I_{th} Temperature Variation	ΔI_{th}		1.5		mA	$T_a=0$ to 85°C
Slope Efficiency	η	0.3	0.4	0.7	W/A	$I_f = 6\text{mA}$
η Temperature Variation	$\Delta\eta / \Delta T$		-0.5		%/ $^{\circ}\text{C}$	$T_a=0$ to 85°C at 6mA
Optical Output Power	P_o		2		mW	$I_f = 6\text{mA}$
Peak Wavelength	λ	840	850	860	nm	$I_f = 6\text{mA}$
λ Temperature Variation	$\Delta\lambda / \Delta T$		0.06			$T_a=0$ to 85°C at 6mA
Spectral Bandwidth (RMS)	$\Delta\lambda$			0.85	nm	$I_f = 6\text{mA}$
Beam Divergence	Θ		2		$^{\circ}$	$P_o=2.0\text{mW}$, (FWHM)
Operating Voltage	V_f		1.8	2.2	V	$I_f = 6\text{mA}$
Breakdown Voltage	V_b		-10		V	
Dynamic Resistance	R_d	20	35	55	Ohm	$I_f = 6\text{mA}$

Notes

* These specifications are subject to change without notice.

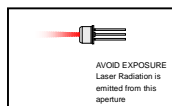
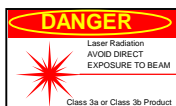

NOTICE

The inherent design of this component causes it to be sensitive to electrostatic discharge(ESD). To prevent ESD-induced damage and/or degradation to equipment, take normal ESD precautions when handling this product

DANGER

The VCSEL is a class IIIb laser and should be treated as a potential eye hazard. Due to the size of the component, the applicable warning logotype, aperture label, and certification / identification label cannot be placed on the component itself.

Characteristics Curves

LIV Curve

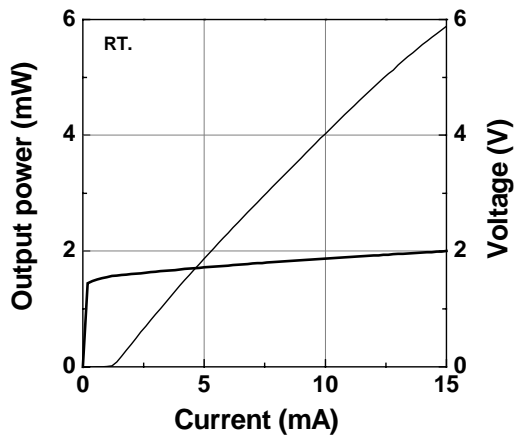

LIV vs Temperature

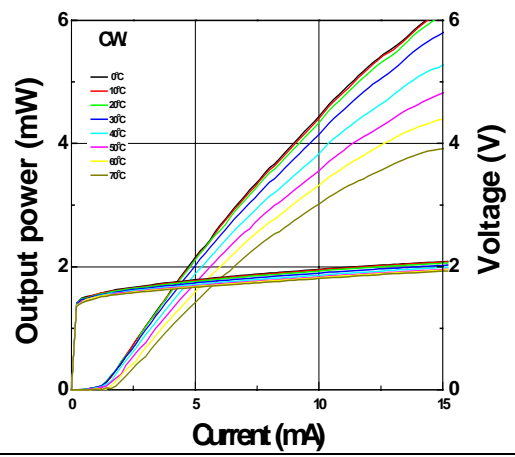

EL Spectrum

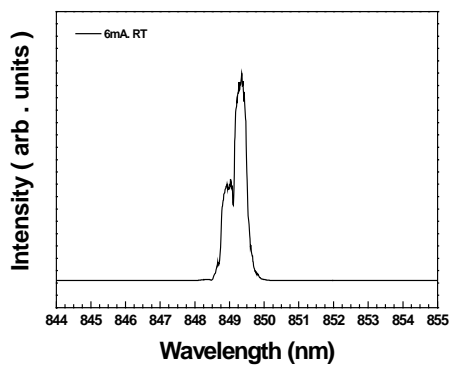

I_{th} vs Temperature

