



UV LED LAMP SPECIFICATION

Model: NS375L-5RLO

Absolute maximum ratings (Ta=25°C)

Item	Symbol	Maximum rating	Unit
DC Forward current	I _F	25	mA
Pulse forward current*1	I _{FP}	100	mA
Power dissipation	P _D	100	mW
Operating temperature	T _{OPR}	-30 to +80	°C
Storage temperature	T _{STG}	-30 to +85	°C
Soldering temperature	T _{SOL}	260°C within 10 seconds	

*1 Conditions: Duty cycle ≤ 1/10, Pulse width ≤ 0.1msec

Optical and electrical characteristics (Ta=25°C)

Item	Symbol	Condition	Min.	Typ.	Max.	Unit
Forward voltage	V _F	I _F =20mA	3.2	3.6	4.2	V
Peak wavelength*2	λ _p	I _F =20mA	375	-	380	nm
Full width at half maximum	Δλ	I _F =20mA	10	-	20	nm
Optical output power *3	Rank 8	Po. I _F =20mA	4.0		6.0	mW
	Rank 9		6.0		8.4	

*2 Measurement error: ±2nm

*3 Measurement error: 10%



• Mechanical test results

Test items	Test conditions	Notes	Test results	
			LTPD	Damages
Terminal strength (Pulling/Pushing)	Load 5N (Pulling) Load 1N(Pushing)	For 10 seconds each	50%	0/5
Terminal strength (Bending)	Load 2.5N 0°to 90°to 0° to reverse direction 90°to 0°	One time	50%	0/5
Dropping damage	Dropping from 1m high	Two times	20%	0/11

• Environmental test results

Test items	Test conditions	Notes	Test results	
			LTPD	Damages
Resistance to soldering heat	Tsol=260±5°C, 10 seconds At 1.5mm from the lead base	One time	10%	0/22
Resistance to soldering heat	Tsol=350±5°C, 3 seconds At 1.5mm from the lead base	One time	10%	0/22
Solderability	Tsol=235±5°C, 5 seconds (using flux)	One time Wetting more than 95%	20%	0/11

• Life test results

Test items	Test conditions	Notes	Test results	
			LTPD	Damages
Steady state operating life	Ta=25±2°C, IF=20mA	1000 hours	10%	0/22
Operating life at high temperature	Ta=80±2°C, IF=10mA	1000 hours	10%	0/22
Storage at high temperature	Ta=85±2°C	1000 hours	10%	0/22
Operating life at low temperature	Ta=-30±2°C, IF=15mA	1000 hours	10%	0/22
Operating life at high temperature and humidity	Ta=60±2°C, RH=90±5%, IF=15mA	500 hours	10%	0/22
Storage at high temperature and humidity	Ta=60±2°C, RH=90±5%	500 hours	10%	0/22

(2) Criteria for judging damages

Test items	Symbols	Measurement conditions	Judgment criteria	
			Min.	Max.
Forward voltage	VF	IF=20mA	-	(U)×1.1
Optical output power	Po	IF=20mA	(L)×0.5	-

*(U): Upper standard level, (L): Lower standard level



■ Optical and electrical characteristics

■ Forward voltage vs. Forward current

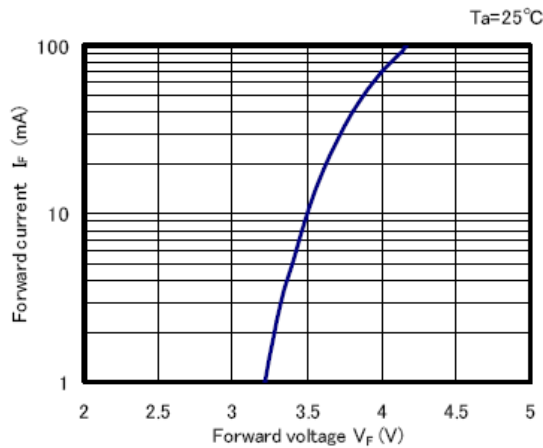

■ Forward current vs. Relative output power

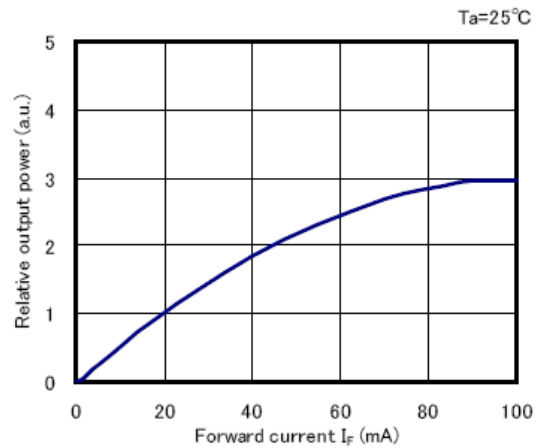

■ Ambient temperature vs. Relative output power

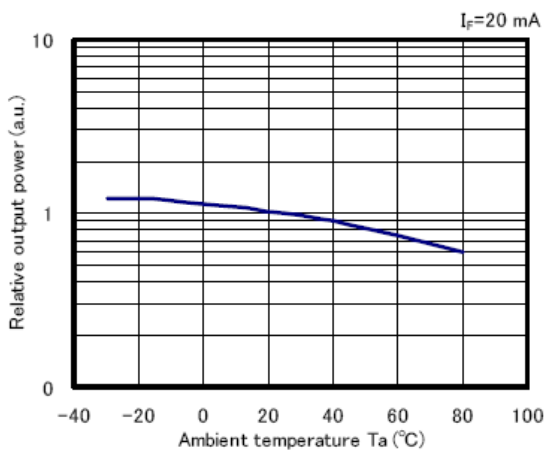

■ Ambient temperature vs. Forward voltage

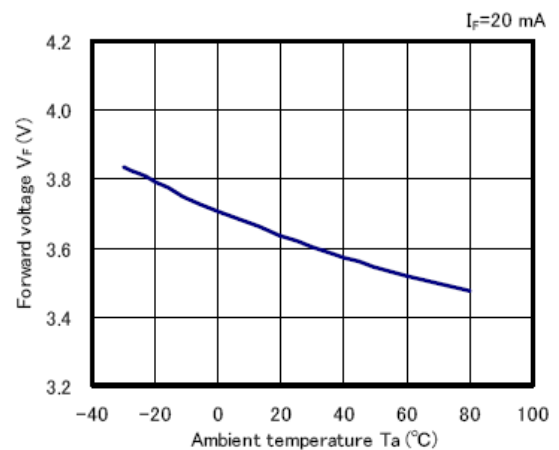



ROITHNER LASERTECHNIK GmbH

WIEDNER HAUPTSTRASSE 76 IO40 VIENNA AUSTRIA
TEL. +43 1 586 52 43 -0, FAX. -44, OFFICE@ROITHNER-LASER.COM



■ Ambient temperature vs.
Allowable forward current

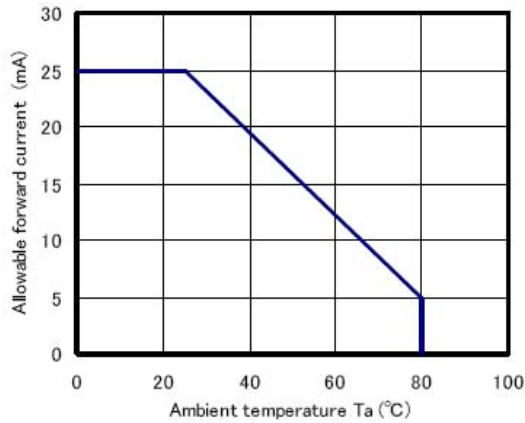

■ Spectrum

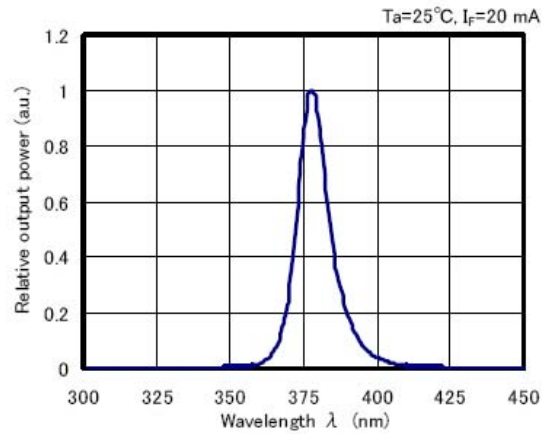

■ Directivity

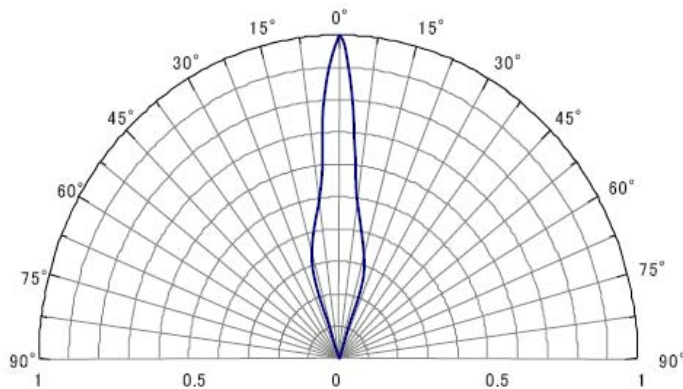



■ Dimensional outline drawing

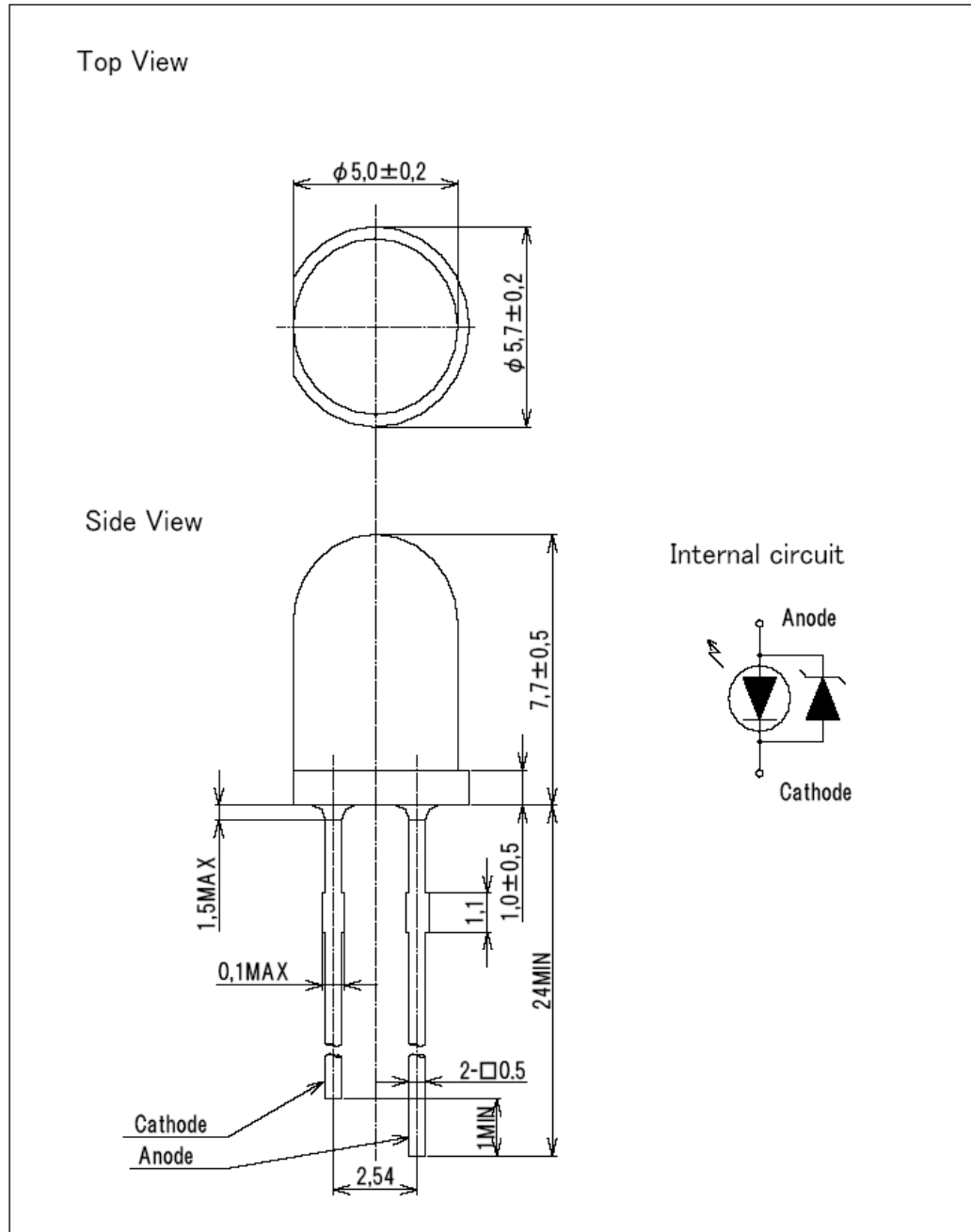

*A zener diode is built in the protective circuit against static electricity.