

ROITHNER LASERTECHNIK

A-1040 VIENNA, SCHOENBRUNNER STRASSE 7, AUSTRIA

TEL: +43 -1- 586 52 43-0 FAX: +43 -1- 586 52 43-44

e-mail: office@roithner-laser.com http://www.roithner-laser.com

UVLED370-110 TECHNICAL DATA



UV LED

Peak Wavelength: **370 nm typ.**
 Output power: **1 mW, cw**
 Package: **TO-46, flat window**

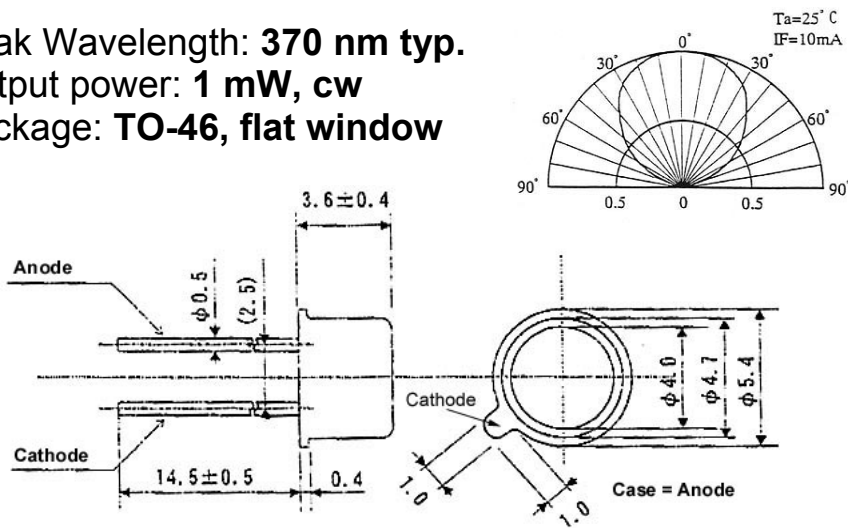

Allowable Forward Current vs. Ambient Temperature

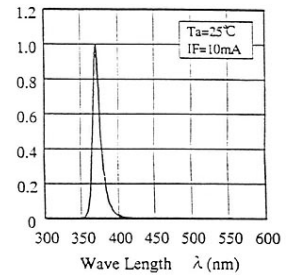
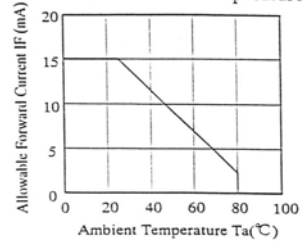

Absolute Maximum Ratings (Tc=25°C)

CHARACTERISTIC	SYMBOL	RATING	UNIT
DC Forward Current	I_F	15	mA
Pulse Forward Current *)	I_{FP}	30	mA
Allowable Reverse Current	I_R	85	mA
Power Dissipation	P_D	60	mW
Operating Temperature	T_{OP}	-30 .. +80	°C
Storage Temperature	T_{STG}	-40 .. +100	°C

*) Pulse width ≤ 10 ms, duty cycle ≤ 0.1

Optical-Electrical Characteristics (Tc = 25°C)

CHARACTERISTIC	SYMBOL	TEST CONDITION	MIN	TYP	MAX	UNIT
DC Forward Voltage	V_F	$I_F = 10$ mA	-	3.9	-	V
Optical Power	P_O	$I_F = 10$ mA	-	1	-	mW
Peak Wavelength	λ_P	$I_F = 10$ mA	-	370	-	nm
Spectrum Half Width	$\Delta\lambda$	$I_F = 10$ mA	-	12	-	nm
Divergence	θ	$I_F = 10$ mA	-	110	-	°



CAUTION

- The UV LED during operation radiates intense UV light.
 - Do not look directly into the UV light during operation of device. This can be harmful to the eyes even for brief period due to the intense UV light.
 - If viewing the UV light is necessary, please use UV filtered glasses to avoid damage by the UV light.
 - If the UV LED in your product might be viewed directly, please affix a caution label to your product to that effect.
- Avoid direct eye exposure to UV light.
 Keep out of reach of children.