

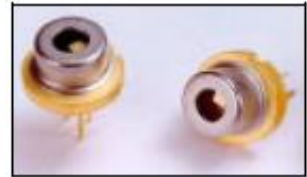

RLT1060-20G



TECHNICAL DATA

Infrared Laser Diode

Features

- Lasing Mode Structure: Single mode
- Peak Wavelength : typ. 1060 nm
- Optical Ouput Power: 20 mW
- Package: 9 mm



Electrical Connection

Pin Configuration	Bottom View								
<p><i>n-type</i></p> <table border="1"> <thead> <tr> <th>PIN</th> <th>Function</th> </tr> </thead> <tbody> <tr> <td>1</td> <td>LD Cathode</td> </tr> <tr> <td>2</td> <td>LD Anode, PD Cathode</td> </tr> <tr> <td>3</td> <td>PD Anode</td> </tr> </tbody> </table>	PIN	Function	1	LD Cathode	2	LD Anode, PD Cathode	3	PD Anode	
PIN	Function								
1	LD Cathode								
2	LD Anode, PD Cathode								
3	PD Anode								

Absolute Maximum Ratings ($T_c=25^\circ\text{C}$)

Item	Symbol	Value	Unit
CW Output Power	P_o	20	mW
Maximum LD Current	I_f	70	mA
Operating Case Temperature	T_c	-20 ... +40	$^\circ\text{C}$
Storage Temperature	T_{stg}	-40 ... +70	$^\circ\text{C}$

Specifications ($T_c=25^\circ\text{C}$)

Item	Symbol	Condition	Min.	Typ.	Max.	Unit
Optical Specification						
CW Output Power	P_o	cw	-	20	-	mW
Peak Wavelength	λ_p	$P_o = 20 \text{ mW}$	1050	1060	1070	nm
Spectral Width (FWHM)	$\Delta\lambda$	$P_o = 20 \text{ mW}$				nm
FWHM Beam Divergence	θ_{\parallel}	$P_o = 20 \text{ mW}$	-	7.5	-	deg
	θ_{\perp}	$P_o = 20 \text{ mW}$	-	43	-	deg
Emitting Aperature	$W \times H$					μm
Electrical Specification						
Threshold Current	I_{th}	cw	-	30	-	mA
Operating Current	I_{op}	$P_o = 20 \text{ mW}$	-	55	-	mA
Operating Voltage	U_{op}	$P_o = 20 \text{ mW}$	-	-	2	V
Monitor Current	I_m	$P_o = 20 \text{ mW}$				μA
Monitor Voltage	U_m	$P_o = 20 \text{ mW}$	-	-	5	V

The above specifications are for reference purpose only and subjected to change without prior notice.



Package Dimensons

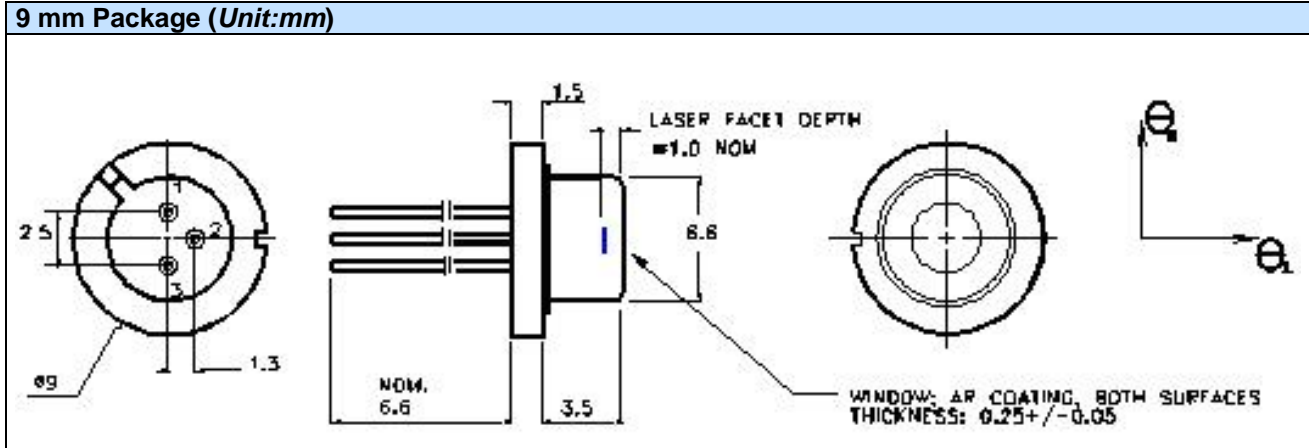

Safety of Laser light

- Laser Light can damage the human eyes and skin. Do not expose the eye or skin directly to any laser light and/or through optical lens. When handling the LDs, wear appropriate safety glasses to prevent laser light, even any reflections from entering to the eye. Focused laser beam through optical instruments will increase the chance of eye hazard.
- These LDs are emitting invisible light.



Cautions

1. Operating methode

- This LD shall change its forward voltage requirement and optical output power according to temperature change. Also, the LD will require more operation current to maintain same output power as it degrades. In order to maintain output power, use of APC (Automatic Power Control) is recommended. Which use monitor feedback to adjust the operation current.
- Confirm that electrical spike current generated by switching on and off does not exceed the maximum operating current level specified herein above as absolute maximum rating. Also, employ appropriate countermeasures to reduce chattering and/or overshooting in the circuit.

2. Static Electricity

- Static electricity or electrical surges will reduce and degrade the reliability of the LDs. It is recommended to use a wrist strap or anti-electrostatic glove when handling the product.

3. Absolute Maximum Rating

- Active layer of LDs shall have high current density and generate high electric field during its operation. In order to prevent excessive damage, the LD must be operated strictly below absolute maximum rating.



NOTE
LASERDIODE
MUST BE COOLED