



ROITHNER LASERTECHNIK GmbH

WIEDNER HAUPTSTRASSE 76
TEL. +43 1 586 52 43 -O. FAX. -44

1040 VIENNA

AUSTRIA

OFFICE@ROITHNER-LASER.COM



RLT1060-30MG

- Infrared Laser Diode
- 1060 nm, 30 mW, SM
- TO56 package, Flat Window



Description



RLT1060-30MG is an infrared Fabry Perot quantum well laser diode, typically emitting at 1060 nm, with a nominal output power of 30 mW. It features single mode emission and wide operating temperature range of up to 60°C. It is an efficient radiation source for many industrial applications. **RLT1060-30MG** comes in 5.6 mm TO-Can package with **integrated monitor photodiode**.

Maximum Ratings* (T_{CASE} = 25°C)

Parameter	Symbol	Values		Unit
		Min.	Max.	
Optical Output Power*1	P_O		35	mW
LD Reverse Voltage	V_{RLD}		2	V
PD Reverse Voltage	V_{RPD}		30	V
Operating Temperature*1	T_{OPR}	- 10	+ 60	°C
Storage Temperature	T_{STG}	- 20	+ 80	°C
Soldering Temperature (max. 3s)	T_{SOL}		+ 260	°C



* operating close to or outside these conditions may damage the device

Electro-Optical Characteristics (T_{CASE} = 25°C)

Parameter	Symbol	Values			Unit
		Min.	Typ.	Max.	
Peak Wavelength	λ_P	1050	1060	1070	nm
Optical Output Power	P_O		30		mW
Spectral Width (FWHM)	$\Delta\lambda$		2		nm
Operating Voltage	V_F		1.4		V
Threshold Current	I_{th}		15		mA
Operating Current	I_F		50		mA
Monitor Current	I_M		0.3		mA
Slope Efficiency	η		0.8		W/A
Beam Divergence (FWHM)	$\theta_{ }, \theta_{\perp}$		9 x 27		deg.

Electrical Connection

Pin Configuration

Pin #	Function
Pin 1	LD cathode
Pin 2 [case]	LD anode, PD cathode
Pin 3	PD anode

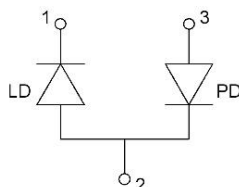

Bottom View

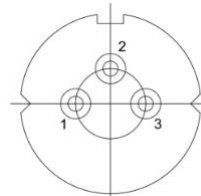



Outline Dimensions

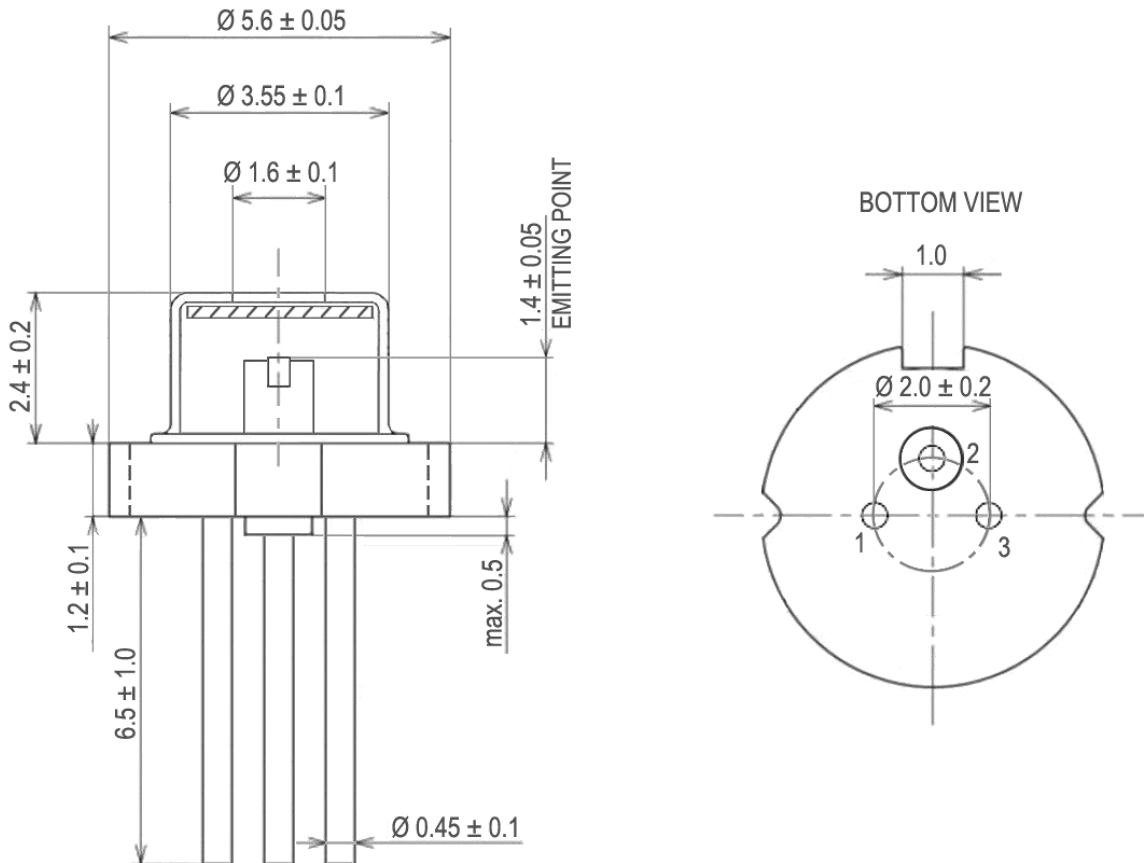

All dimensions in mm

Precautions

Safety

Caution: This laser diode emits highly concentrated light which can be **hazardous to the human eye and skin**. This diode is classified as **CLASS 3B laser product** according to IEC 60825-1 and 21 CFR Part 1040.10 Safety Standards.

ESD caution

Always do handle laser diodes with extreme care to **prevent electrostatic discharge**, the primary cause of unexpected diode failure. To prevent ESD related failures, it is strongly advised to always **wearing wrist straps**, and **grounding all applicable work surfaces**, when handling laser diodes

Operating considerations

It is strongly advised to only operate this laser diode with a current source. The current of a laser diode is an exponential function of the voltage across it. **Usage of current regulated drive circuits is mandatory.** Laser diodes may be damaged by excessive drive currents or switching transients. **Proper heat sinking will greatly enhance stability and lifetime of the laser diode**