



ROITHNER LASERTECHNIK GmbH

WIEDNER HAUPTSTRASSE 76
TEL. +43 1 586 52 43 -O. FAX. -44

1040 VIENNA AUSTRIA
OFFICE@ROITHNER-LASER.COM



RLT1064-220GS

- IR High Power Laser Diode
- 1064 nm, 220 mW
- Single transverse mode
- 9 mm TO-Can with PD



Description

RLT1064-220GS is an infrared high power laser diode, typically emitting at **1064 nm**, with a nominal output power of **220 mW**. It features **single transverse mode** emission and maximum operating temperature of 40°C. **RLT1064-220GS** comes in 9 mm TO-Can package with **integrated monitor photodiode**

Maximum Ratings*

| Parameter | Symbol | Values | | Unit |
|---------------------------------|-----------|--------|-------|------|
| | | Min. | Max. | |
| Reverse Voltage | V_R | | 2 | V |
| Operating Temperature* | T_{OPR} | - 10 | + 40 | °C |
| Storage Temperature* | T_{STG} | - 40 | + 85 | °C |
| Soldering Temperature (max. 3s) | T_{SOL} | | + 260 | °C |

* operating close to or outside these conditions may damage the device

Electro-Optical Characteristics ($T_{CASE} = 25^\circ\text{C}$)

| Parameter | Symbol | Values | | | Unit |
|------------------------|------------------|------------------------|-------------|-------------|-----------|
| | | Min. | Typ. | Max. | |
| Peak Wavelength | λ_P | 1050 | 1064 | 1079 | nm |
| Spectral Width | λ_Δ | | 2.0 | | nm |
| Optical Output Power | P_O | | 220 | | mW |
| Operating Voltage | V_F | | 1.8 | | V |
| Threshold Current | I_{th} | | 50 | | mA |
| Operating Current | I_F | | 330 | | mA |
| Slope Efficiency | η | | 0.75 | | W/A |
| Spatial Mode | | Single transverse mode | | | |
| Beam Divergence (FWHM) | parallel | $\Theta_{ }$ | 10 | | deg. |
| | perpendicular | Θ_{\perp} | 35 | | deg. |



Electrical Connection

| Pin Configuration | | Bottom View | |
|-------------------|----------------------|-------------|--|
| Pin # | Function | | |
| 1 | LD cathode | | |
| 2 [case] | LD anode, PD cathode | | |
| 3 | PD anode | | |





Outline Dimension

TO-9

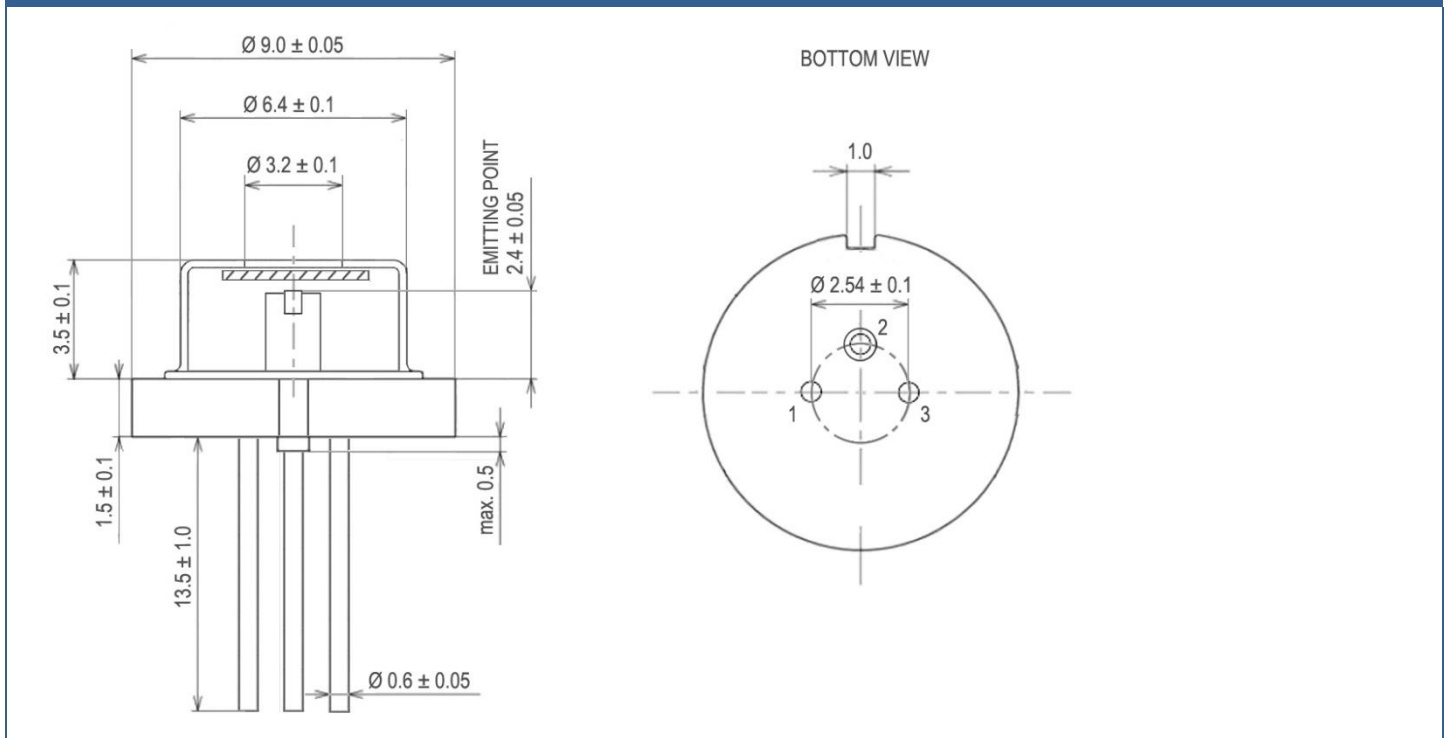

All dimensions in mm

Precautions

Safety

Warning: Invisible laser radiation is emitted from this device!

Caution: Laser light emitted from any laser diode may be **harmful to the human eye**. Avoid looking directly into the laser diode's aperture when the diode is in operation.

Note: The use of optical lenses with this laser diode will increase eye hazard

ESD caution

Always do handle laser diodes with extreme care to **prevent electrostatic discharge**, the primary cause of unexpected diode failure. To prevent ESD related failures, it is strongly advised to always **wearing wrist straps**, and **grounding all applicable work surfaces**, when handling laser diodes

Operating Considerations

It is strongly advised to only operate this laser diode with a current source. The current of a laser diode is an exponential function of the voltage across it. **Usage of current regulated drive circuits is mandatory**. Laser diodes may be damaged by excessive drive currents or switching transients

It is advised, to operate the laser diode at the lowest temperature possible, and to never exceed maximum specifications as outlined in the datasheet. Device degradation will accelerate with increased temperature. **Proper heat sinking will greatly enhance stability and lifetime of the laser diode**