



RLT420-10MG

- Blue Laser Diode
- 420 nm, 10 mW
- Single Transverse Mode
- 5.6 mm TO Package



Description

RLT420-10MG is a blue **single transverse mode** laser diode, based on InGaN quantum structure, with a peak wavelength of 420 nm, and **narrow peak wavelength tolerance of ± 2 nm** (± 1 nm optionally available). **RLT420-10MG** comes in 5.6 mm TO-Can package.

Maximum Ratings*

Parameter	Symbol	Values		Unit
		Min.	Max.	
Reverse Voltage	U_R		5	V
Optical Output Power	P_O		40	mW
Operating Temperature	T_{OPR}	0	+ 50	°C
Storage Temperature	T_{STG}	- 20	+ 80	°C
Soldering Temperature (max. 3s)	T_{SOL}		+ 260	°C

* Operating close to or outside these conditions may damage the device

Electro-Optical Characteristics ($T_{CASE} = 20^\circ\text{C}$, $P_O = 10\text{ mW}$)

Parameter	Symbol	Values			Unit	Condition
		Min.	Typ.	Max.		
Peak Wavelength [$T_{CASE}=20^\circ\text{C}$]	λ_P	418	420	422	nm	$P_O=10\text{mW}$
Peak Wavelength [$T_{CASE}=20^\circ\text{C}$]	λ_P	419*	420	421*	nm	$P_O=10\text{mW}$
Spectral Width (FWHM)	$\Delta\lambda$		1		nm	$P_O=10\text{mW}$
Temperature Coefficient	$\Delta\lambda/\Delta T$		0.05		nm/°C	$P_O=10\text{mW}$
Operating Voltage	U_F		4.5	7.0	V	$P_O=10\text{mW}$
Threshold Current	I_{th}		40	95	mA	$P_O=10\text{mW}$
Operating Current	I_F		65	120	mA	$P_O=10\text{mW}$
Beam Divergence (FWHM)	parallel	$\Theta_{ }$	7		deg.	$P_O=10\text{mW}$
	perpendicular	Θ_{\perp}	30		deg.	$P_O=10\text{mW}$

* ± 1 nm available optionally



Electrical Connection

Pin Configuration [subject to change]		Bottom View
Pin #	Function	
Pin 1	LD Anode	
Pin 2 [case]	Not connected	
Pin 3	LD Cathode	

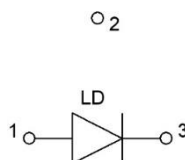



Outline Dimensions

5.6 mm TO-Can

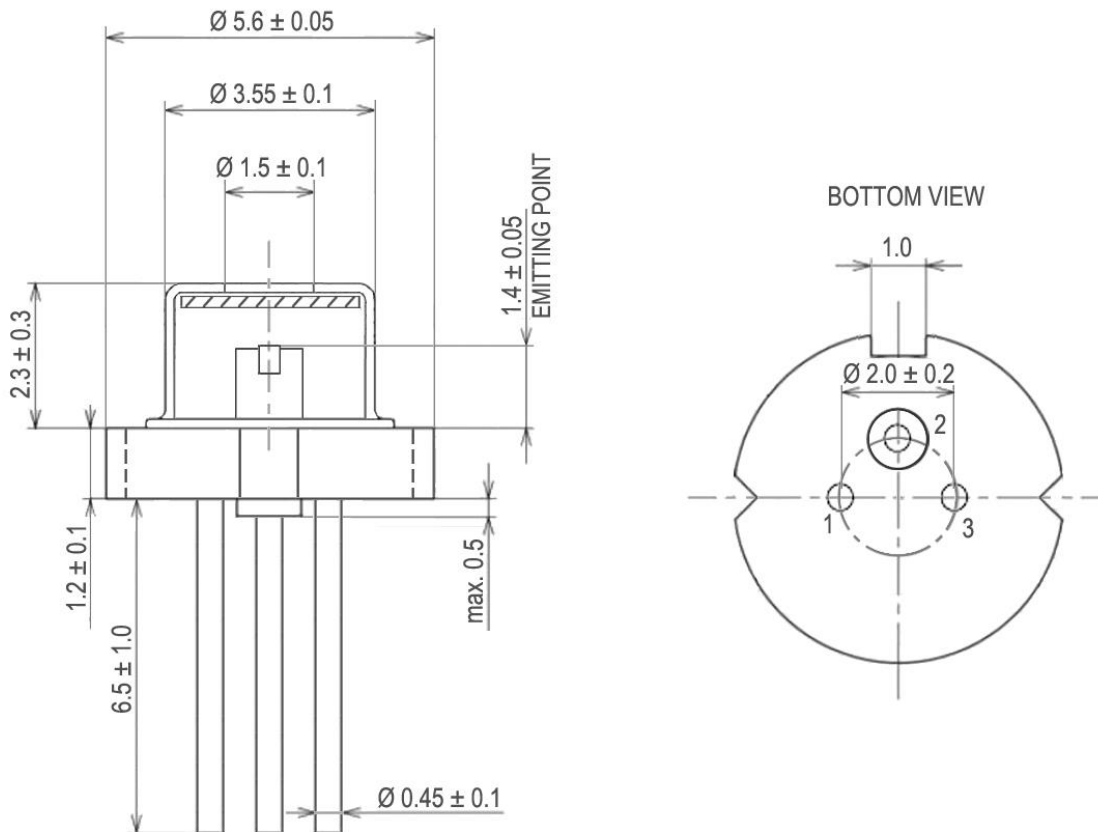

All dimensions in mm

Precautions

Safety

Caution: Laser light emitted from any laser diode may be **harmful to the human eye**. Avoid looking directly into the laser diode's aperture when the diode is in operation.

Note: The use of optical lenses with this laser diode will increase eye hazard

ESD caution

Always do handle laser diodes with extreme care to **prevent electrostatic discharge**, the primary cause of unexpected diode failure. To prevent ESD related failures, we do advise to always **wearing wrist straps**, and **grounding all applicable work surfaces**, when handling laser diodes.

Operating considerations

We do advise to operate this laser diode with a current source only. The current of a laser diode is an exponential function of the voltage across it. **Usage of current regulated drive circuits is mandatory**. Laser diodes may be damaged by excessive drive currents or switching transients.

Proper heat sinking will greatly enhance stability and lifetime of the laser diode