



## RLT880-3W-C

- IR Laser Diode
- 880 nm, 3.0 W
- Multi Transverse Mode
- C-Mount



### Description



RLT880-3W-C is a red high power CW laser diode, typically emitting at 880 nm. It features multi transverse mode emission and a **maximum operating temperature of 30°C**. RLT880-3W-C comes in C-mount package, and has been designed for industrial application. Fast axis collimation lens (FAC) is optionally available

### Maximum Rating\*

Parameter	Symbol	Values		Unit
		Min.	Max.	
Reverse Voltage	$U_R$		2	V
<b>Operating Temperature*</b>	$T_{OPR}$	<b>+ 10</b>	<b>+ 30</b>	°C
Storage Temperature*	$T_{STG}$	- 20	+ 80	°C
Soldering Temperature (max. 3s)	$T_{SOL}$		+ 260	°C

\* operating close to or outside these conditions may damage the device

### Electro-Optical Characteristics ( $T_{CASE} = 25^\circ\text{C}$ )

Parameter	Symbol	Values			Unit
		Min.	Typ.	Max.	
<b>Peak Wavelength</b>	$\lambda_P$	<b>870</b>	<b>880</b>	<b>890</b>	nm
Optical Output Power	$P_O$		3.0		W
Spectral Width (FWHM)	$\lambda_\Delta$		2.0		nm
<b>Recommended Operating Temperature</b>	$T_{OPR}$		<b>25</b>		°C
Emitting Area			150 x1		$\mu\text{m}$
Operating Voltage	$U_F$		1.8		V
Threshold Current	$I_{th}$		0.5		A
Operating Current	$I_F$		3.3		A
Temperature Coefficient	$\alpha$		0.3		nm/°C
Slope Efficiency	$\eta$		1.1		W/A
Beam Divergence (FWHM)	parallel	$\Theta_{  }$	8		deg.
	perpendicular	$\Theta_{\perp}$	35		deg.





## Outline Dimensions (subject to change)

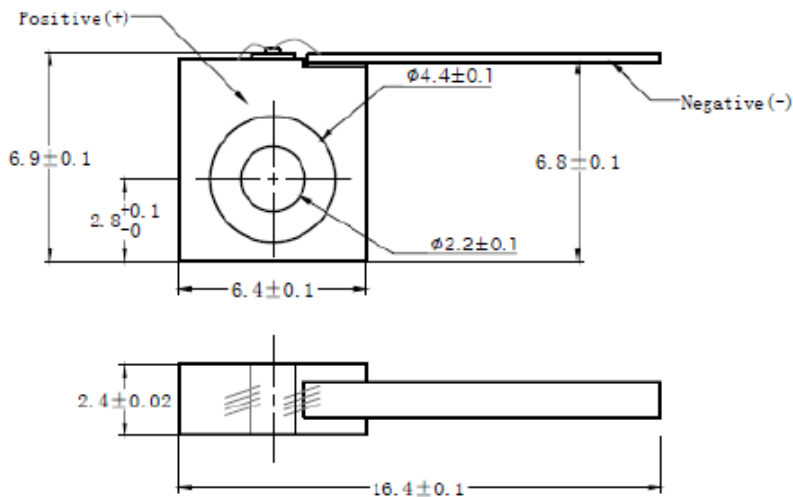

All dimensions in mm

## Precautions

### Safety

**Caution:** This laser diode emits highly concentrated light which can be **hazardous to the human eye and skin**. This diode is classified as **CLASS 4 laser product** according to **IEC 60825-1** and **21 CFR Part 1040.10 Safety Standards**.

**Note:** The use of optical lenses with this laser diode will increase eye hazard

### ESD caution

Always do handle laser diodes with extreme care to **prevent electrostatic discharge**, the primary cause of unexpected diode failure. To prevent ESD related failures, it is strongly advised to always **wearing wrist straps**, and **grounding all applicable work surfaces**, when handling laser diodes



### Operating Considerations

It is strongly advised to only operate this laser diode with a current source. The current of a laser diode is an exponential function of the voltage across it. **Usage of current regulated drive circuits is mandatory**. Laser diodes may be damaged by excessive drive currents or switching transients

It is advised, to operate the laser diode at the lowest temperature possible, and to never exceed maximum specifications as outlined in the datasheet. Device degradation will accelerate with increased temperature. **Proper heat sinking will greatly enhance stability and life time of the laser diode**