



ROITHNER LASERTECHNIK GmbH

WIEDNER HAUPTSTRASSE 76
TEL. +43 1 586 52 43 -0. FAX. -44

1040 VIENNA AUSTRIA
OFFICE@ROITHNER-LASER.COM



RV1-370-15-5

- UV Light Emitting Diode
- 370 nm, 4.0 mW
- 5 mm UV-resistant clear epoxy resin
- Beam Half Angle: $\pm 7.5^\circ$



Description

RV1-370-15-5 is an ultraviolet LED, typically emitting at **370 nm** with an optical output power of **4.0 mW @ 20 mA**. It comes in a hermetically sealed clear 5 mm **UV-resistant** clear epoxy resin with a beam angle of 15°

Maximum Rating ($T_{CASE} = 25^\circ C$)

Parameter	Symbol	Values		Unit
		Min.	Max.	
Power Dissipation, DC	P_D		114	mW
DC Forward Current*	I_F		30	mA
Pulse Forward Current*	I_{FP}		100	mA
Reverse Voltage	V_R		5	V
Operating Temperature	T_{OPR}	- 30	+ 85	$^\circ C$
Storage Temperature	T_{STG}	- 40	+ 100	$^\circ C$
Soldering Temperature (max 5s)	T_{SOL}		+ 260	$^\circ C$

* Duty cycle max. 10%, Pulse width max 10ms

Electro-Optical Characteristics ($T_{CASE} = 25^\circ C, I_F = 20 \text{ mA}$)

Parameter	Symbol	Values			Unit
		Min.	Typ.	Max.	
Peak Wavelength	λ_P	365	370	375	nm
Forward Voltage	V_F	3.0	3.4	3.8	V
Reverse Current ($V_R = 5V$)	V_R			10	μA
Radiant Flux	Φ_E	2.0	4.0		mW
Beam Half Angle	$\Theta_{1/2}$		7.5		deg.

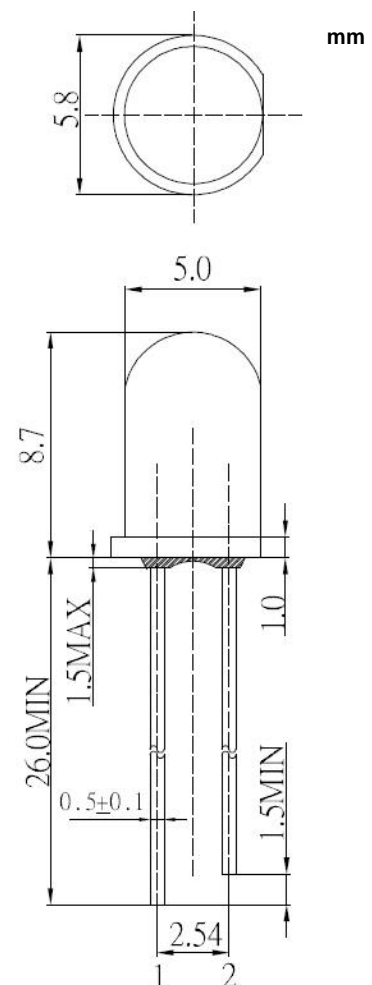

1: Anode
2: Cathode





Performance Characteristics

Radiation Characteristics

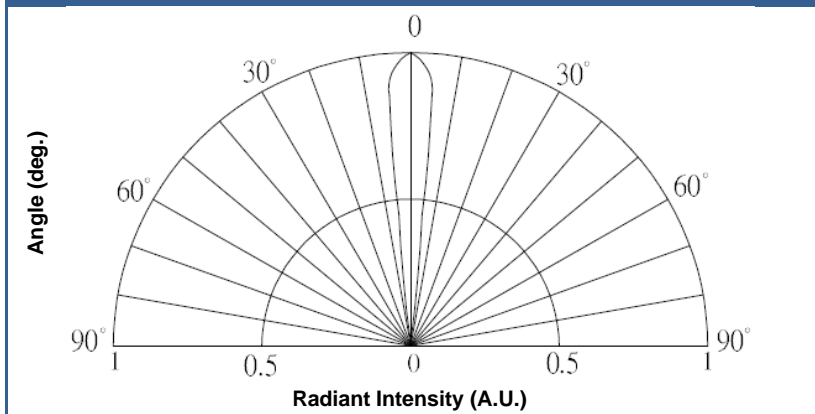

General Notes

Soldering

- Do avoid overheating of the LED
- Do avoid electrostatic discharge (ESD)
- Do avoid mechanical stress, shock, and vibration
- Do only use non-corrosive flux
- Do not apply current to the LED until it has cooled down to room temperature after soldering

Cleaning

- **Cleaning with isopropyl alcohol, propanol, or ethyl alcohol is recommended**
- DO NOT USE acetone, chloroform, trichloroethylene, or MKS
- DO NOT USE ultrasonic cleaners

Static Electricity

- **LEDs are sensitive to electrostatic discharge (ESD).**
- Precautions against ESD must be taken when handling or operating these LEDs
- Surge voltage or electrostatic discharge can result in complete failure of the LED.

Radiation

- During operation these LEDs do emit light, which **could be hazardous to skin and eyes**
- Do avoid exposure to the emitted light. Protective glasses if needed
- It is further advised to attach a warning label on products/systems.

Operation

- **Do only operate LEDs with a current source.**
- Running these LEDs from a voltage source will result in complete failure of the device.
- Usage of current regulated drive circuits is mandatory.